

Air Monitoring Program
Quality Assurance Project Plan
Area 1, Phase 1 Development
Version 1

Baltimore Works Site
Baltimore, Maryland

March 2014

By:
Environmental Resources Management Inc.
Harbor Point Development LLC

For:
U.S. Environmental Protection Agency - Region III
Maryland Department of the Environment

**APPROVAL AND SIGNATURE PAGE FOR THE AIR MONITORING PROGRAM
QUALITY ASSURANCE PROJECT PLAN AREA 1, PHASE I DEVELOPMENT,
VERSION 1, FEBRUARY 24, 2014.**

	<u>Approval</u>	<u>Date</u>
Project Manager (Harbor Point Development LLC)	_____ Jonathan Flesher	_____
Project Manager (Honeywell International)	_____ Chris French	_____
Project Manager (ERM, Inc.)	_____ Darren Quillen, P.E.	_____
Project Quality Assurance Manager (ERM, Inc.)	_____ Larry Hottenstein	_____
Partner-in-Charge (ERM, Inc.)	_____ Leonard Rafalko	_____

A signed copy of this Air Monitoring Program Quality Assurance Project Plan is stored in the Harbor Point Development office. Please see the contact in the Acknowledgement Section.

REVISION HISTORY FOR THE AIR MONITORING PROGRAM QUALITY ASSURANCE PROJECT PLAN AREA 1, PHASE I DEVELOPMENT, VERSION 1, FEBRUARY 24, 2014

Date	Revision Description	Initials

TABLE OF CONTENTS

TABLE OF CONTENTS	III
1.0 PROJECT MANAGEMENT	1
1.1 ROLES AND RESPONSIBILITIES	1
1.2 PROJECT BACKGROUND, OVERVIEW, AND INTENDED USE OF DATA	5
1.3 DATA QUALITY OBJECTIVES	6
1.3.1 <i>State the Problem</i>	7
1.3.2 <i>Identify the Decision</i>	7
1.3.3 <i>Identify Inputs to the Decision</i>	8
1.3.4 <i>Define the Site Boundaries</i>	11
1.3.5 <i>Develop a Decision Rule</i>	12
1.3.6 <i>Specify Limits on Decision Errors</i>	13
1.3.7 <i>Optimize the Sampling Design</i>	14
1.4 MEASUREMENT PERFORMANCE CRITERIA	15
2.0 SPECIAL TRAINING REQUIREMENTS AND CERTIFICATION	17
2.1 DOCUMENTATION AND RECORDS REQUIREMENTS	17
3.0 DATA ACQUISITION	19
3.1 SAMPLE COLLECTION PROCEDURES, DESIGN, & SAMPLING TASKS	
OVERVIEW	19
3.1.1 <i>Pre-Construction Air Monitoring</i>	19
3.1.2 <i>Construction Air Monitoring</i>	22
3.2 SAMPLING PROCEDURES AND REQUIREMENTS	26
3.3 SAMPLING HANDLING, CUSTODY PROCEDURES, AND DOCUMENTATION	27
3.4 ANALYTICAL METHOD REQUIREMENTS	30
3.5 FIELD QUALITY CONTROL REQUIREMENTS	30
3.6 FIELD INSTRUMENT/EQUIPMENT CALIBRATION AND MAINTENANCE REQUIREMENTS	30

3.7	LABORATORY QUALITY CONTROL REQUIREMENTS	33
3.8	DATA MANAGEMENT REQUIREMENTS	34
4.0	ASSESSMENTS	36
	4.1.1 <i>Sampling Program Design Execution</i>	36
	4.1.2 <i>Sample Collection Procedures</i>	36
	4.1.3 <i>Sample Handling</i>	37
	4.1.4 <i>Quantitative Field Data</i>	37
	4.2.1 <i>Laboratory Data Review and Reduction</i>	37
	4.2.2 <i>Laboratory Data Review and Validation</i>	38
4.3	AUDITS OF DATA QUALITY	38
	4.3.1 <i>Performance Audits</i>	39
	4.3.2 <i>System Audits</i>	40
4.4	SURVEILLANCE OF OPERATIONS	41
4.5	ASSESSMENT OF DATA QUALITY	42
	4.5.1 <i>Field Data Quality</i>	42
	4.5.2 <i>Laboratory Data Reduction</i>	44
4.6	QUALITATIVE AND QUANTITATIVE COMPARISONS TO ACCEPTANCE CRITERIA	45
	4.6.1 <i>Precision</i>	45
	4.6.2 <i>Accuracy</i>	46
	4.6.3 <i>Representativeness</i>	46
	4.6.4 <i>Comparability</i>	47
	4.6.5 <i>Completeness</i>	47
	4.6.6 <i>Sensitivity (Method Detection Limit)</i>	47
4.7	INTERIM ASSESSMENTS OF DATA QUALITY	48
5	REVIEW, EVALUATION OF USABILITY AND REPORTING REQUIREMENTS	49
5.1	DATA VERIFICATION AND VALIDATION TARGETS AND METHODS	49
5.3	POTENTIAL LIMITATIONS ON DATA INTERPRETATION	52
5.4	RECONCILIATION WITH PROJECT REQUIREMENTS	53
	5.4.1 <i>Conduct Preliminary Data Review</i>	53
	5.4.2 <i>Draw Conclusions from the Data</i>	53
5.5	REPORTS TO MANAGEMENT	53
	5.5.1 <i>Daily Data Summary Tables</i>	53

5.5.2	<i>Event Logs</i>	53
5.5.3	<i>Data Quality Assessment Reports</i>	54
5.5.4	<i>Performance Evaluation and Audit Reports</i>	54
5.5.5	<i>Summary Data Reports</i>	54

LIST OF TABLES

1	<i>Roles and Responsibilities</i>
2	<i>Measurement Quality Objectives</i>
3.	<i>Records and Storage Locations</i>
4	<i>Pre-construction Monitoring Samples</i>
5	<i>Construction Monitoring Samples</i>
6	<i>Field Calibration, Testing, and Inspection</i>
7	<i>Field Equipment Maintenance, Testing, and Inspection</i>

LIST OF FIGURES

1	<i>Project Organization</i>
2	<i>Project Area</i>
3	<i>Pre-construction Air Monitoring Locations</i>
4	<i>Construction Air Monitoring Locations</i>
5	<i>Data Management Process</i>

LIST OF APPENDICES

- A** *Sampling and Analysis Plans (Pre-construction SAP attached;
Construction SAP to be prepared and amended to the QAPP)*

- B** *Field Sampling Method SOP*
 - B1.** *Field Sampling Protocol and Standard Operating Procedure -
Real-Time Air Sampling for Total Particulate Matter in Ambient Air*

 - B2.** *Field Sampling Protocol and Standard Operating Procedure -
Sampling of Hexavalent Chromium in Ambient Air*

- C** *Laboratory Analytical Method SOP*

- D** *Standard Operating Procedure for Response Actions and Notifications*

LIST OF ACRONYMS

BTV - Background Threshold Value

CFR - Code of Federal Regulations

CL - Confidence Limit

COC - Chain of Custody

CrVI - Hexavalent Chromium

° C - Degrees Celsius

° F - Degrees Fahrenheit

DQO - Data Quality Objectives

EPA - U.S. Environmental Protection Agency

ERG - Eastern Research Group

ERS - Environmental Remediation System

IDC - Initial Demonstration of Capability

Lpm - Liters per Minute

M³ - Cubic Meters

MDE - Maryland Department of the Environment

µg - Microgram

mg - Milligram

ng - Nanogram

PAM - Perimeter Air Monitoring

LIST OF ACRONYMS (continued)

PM - Particulate Matter

QA - Quality Assurance

QAPP - Quality Assurance Project Plan

QC - Quality Control

SAP - Sampling and Analysis Plan

SOP - Standard Operating Procedures

SSO - Site Safety Officer

Total PM - Total Particulate Matter

µg - Microgram

µm - Micron

USL - Upper Simultaneous Limit

DOCUMENT DISTRIBUTION LIST

QAPP Recipient	Project Role	Organization	Address / E-mail / Phone
Russell Fish	Project Coordinator	EPA Region 3	Office of Remediation 3LC20 1650 Arch Street Philadelphia, PA 19103-2029 fish.russell@epa.gov (215) 814-3226
Ruth Prince	Technical Lead	EPA Region 3	Office of Technical and Administrative Support 3LC10 1650 Arch Street Philadelphia, PA 19103-2029 prince.ruth@epa.gov (215) 814-3118
Edward Dexter	Project Coordinator	MDE	Solid Waste Program 1800 Washington Boulevard, Suite 605 Baltimore, MD 21230-1719 ed.dexter@maryland.gov (410) 537-3315
Mark Mank	Technical Lead	MDE	Solid Waste Program 1800 Washington Boulevard, Suite 605 Baltimore, MD 21230-1719 mark.mank@maryland.gov (410) 537-3437
Jonathan Flesher	Project Manager	Harbor Point Development LLC (HPD)	1300 Thames Street Suite 10 Baltimore, MD 21231 jflesher@beattydevelopment.com (410) 332-1100
Chris French	Project Manager	Honeywell International	101 Columbia Road Morristown, NJ 07960 chris.french@honeywell.com (973) 455-4131
Julie Swift	Laboratory Program Manager	Eastern Research Group. Inc. (ERG)	601 Keystone Park Drive Suite 700 Morrisville, NC 27560 julie.swift@erg.com (919) 468-7924
Darren Quillen	Project Manager	Environmental Resources Management,	200 Harry S Truman Parkway, Suite 400 Annapolis, Maryland 21401 darren.quillen@erm.com

		Inc. (ERM)	(410) 972-0234
Larry Hottenstein	Quality Assurance Manager	ERM	2875 Michelle Drive Suite 200 Irvine, CA 92606 larry.hottenstein@erm.com (949) 623-4685
Jeff Boggs	Technical Lead	ERM	75 Valley Stream Parkway Suite 200 Malvern, PA 19355 jeff.boggs@erm.com (443) 803-8495

1.0 PROJECT MANAGEMENT

The project consists of air monitoring before and during construction at the Harbor Point Area 1, Phase 1 Development site. The QAPP outline and format are consistent with the policies and guidance specified in the *EPA Guidance on Quality Assurance Project Plans (CIO 2106-G-05 QAPP)*, EPA, 2012. The QAPP presents the rationale and scope of work associated with field activities (e.g., sample types, sample locations), the project data quality objectives, protocols for collecting samples, field and laboratory analytical procedures, quality assurance/quality control (QA/QC) procedures, data quality evaluation criteria, and procedures for documenting field and laboratory methods so that data are technically and legally defensible.

1.1 ROLES AND RESPONSIBILITIES

The project team will consist of personnel from HPD, ERM, and Eastern Research Group (ERG). ERG has been selected to perform the hexavalent chromium (CrVI) analysis. An independent third-party data validator, Laboratory Data Consultants, Inc. (LDC), will validate the data collection, including 40% raw data re-calculation. The following paragraphs describe the major positions and responsibilities of the team along with the approach to quality assurance management. The EPA is the lead regulatory agency for this program with key input from the MDE's Air and Radiation Program. Key project personnel and regulatory personnel and their responsibilities for QA activities are described below. The Project Organization chart (Figure 1) presents the lines of communication and data flow between the individuals listed below on Table 1.

Table 1. Roles and Responsibilities

Name	Title/Role	Organizational Affiliation	Responsibilities
Jonathan Flesher	Project Manager	HPD	<ul style="list-style-type: none"> • Oversees all project activities. • Directs the scope of work to the ERM PM. • Reviews and approves all documents and coordinate transmittal of documents to appropriate parties for review. • Communicates with stakeholders regarding project activities.
Lenny Rafalko	Partner-in-Charge	ERM	<ul style="list-style-type: none"> • Oversees entire program for ERM. • Reviews all final deliverables and invoices. • Seeks HPD feedback on performance of project managers. • Addresses program-level issues.
Darren Quillen	Project Manager	ERM	<ul style="list-style-type: none"> • Reports to ERM Partner-in-Charge (Leonard Rafalko) and HPD (Jonathan Flesher) • Directs ERM Field Manager and subcontractors. • Communicates questions or issues to Agency leads (Ed Dexter, MDE and Russell Fish, EPA) • Ensures that assigned staff has been trained in SOP implementation. • Ensures that all key decisions and project deliverables are subjected to independent technical review by qualified personnel within the time frame of the project schedule.

Name	Title/Role	Organizational Affiliation	Responsibilities
Larry Hottenstein	QA/QC Manager	ERM	<ul style="list-style-type: none"> • Monitor subcontractor (CrVI analysis) for compliance with both project and data quality requirements records, costs, and progress of the work and re-plan and re-schedule work tasks as appropriate. • Ensure and document that QC checks on field equipment are performed according to schedule and meet acceptance criteria, and the QA/QC • Resolves field QA/QC issues. • Audit sample preservation, handling, transport, and custody procedures throughout the project. • Review and approve all data reduction and reporting procedures for inclusion in deliverables. • Conduct Field audits. • Review and respond to field audit assessment findings, determine the root cause for any nonconformance, confer with the ERM PM and Partner in Charge on the steps to be taken for correction, and ensure that procedures are modified to reflect the corrective action and are distributed to all field personnel, including subcontractors. • Report QA and any procedural problems to the ERM PM and Partner in Charge

Name	Title/Role	Organizational Affiliation	Responsibilities
Jeff Boggs	Technical Lead/ Field Manager	ERM	<ul style="list-style-type: none"> • Provide technical support to ERM’s PM, QA Manager, and Field Engineer as needed. • Reports to ERM PM. • Prepares and implements this QAPP and deliverables. • Ensures data collection activities are consistent with approved SAP, SOP and QAPP requirements. • Oversees evaluation of data received from the laboratory in accordance with the project requirements. • Prepares or oversees the preparation of portions of the reports that summarize data results and present conclusions.
Charles McClellan	Field Engineer	ERM	<ul style="list-style-type: none"> • Performs monitoring and collects samples according to project approved SAPs, SOPs and this QAPP. • Reports to ERM Field Manager (if Field Manager not available, report to ERM PM). • Communicates any problems or deviations from project plans to ERM Field Manager. • Ensures that all data collection and handling activities comply with applicable SOPs, including audits conducted in the presence of Agency personnel. • Prepares and maintains field forms, notebooks, and equipment. • Implements technical procedures applicable to tasks. • Inspects and accepts supplies and consumables. • Coordinates and schedules sample shipment to analytical laboratory to meet holding times and analytical procedure specifications.

Name	Title/Role	Organizational Affiliation	Responsibilities
Julie Swift	Project Manager	ERG	<ul style="list-style-type: none"> • Reviews and implements analytical laboratory elements of this QAPP with regards to the CrVI analysis. • Manages analytical chemists to complete the sample analyses selected in this QAPP, according to the approved methods. • Monitors, reviews, and documents the quality of all analytical chemistry work performed by ERG under this QAPP. • Oversees management of analytical data. • Transmits completed data packages to the ERM Quality Manager • Promptly informs the ERM's Quality Manager of any laboratory analytical problems, data quality issues, or delays in sample analysis. • Promptly responds to any data quality issues identified through the independent data validation process.

1.2 ***PROJECT BACKGROUND, OVERVIEW, AND INTENDED USE OF DATA***

The Harbor Point, Area 1, Phase 1 Development will occur at a location (the site) that was formerly a chromium chemical manufacturing facility. The site is located on a peninsula on the northeast shore of the Patapsco River of the Inner Harbor, in the Fells Point section of Baltimore City, Maryland. The historical manufacturing processes at the site resulted in chromium impacts to soil and groundwater. The original buildings and associated infrastructure have been removed from the site, and a number of remedial actions are on-going. An Environmental Remediation System (ERS) is maintained and operated by Honeywell International Inc. (Honeywell) to contain CrVI -impacted ground water and control the potential for human exposure to affected soil in "Area 1" of the site (Figure 2). Area 1 was the principal site of Honeywell's Baltimore Works

Facility where chromium ore was processed from 1845 to 1985. The ERS consists of a Multimedia cap (MMC), Hydraulic barrier, Head Maintenance System (HMS), a ground water storage and transfer system, and Outboard Embankment. The HMS maintains an inward ground water gradient to mitigate the migration of chromium-impacted ground water from the site.

The primary concern addressed by this Air Monitoring Program QAPP is the potential for particulates containing CrVI to be distributed on-site and off-site during the period of construction that involves the disturbance of contaminated materials below the MMC. CrVI is considered by the EPA to be a known human carcinogen by the inhalation route of exposure (EPA 2013). Inhalation of CrVI dusts is also associated with non-cancer toxicity.

Because of the dynamic nature of dust-disturbing activities during construction, providing real time information on concentration levels of particulates to project personnel during construction is necessary in order that dust-generating activities on site can be appropriately controlled. Real-time instrumentation is available to measure ambient concentrations of total particulate matter (Total PM), but such instrumentation is not available for measuring CrVI concentrations in real-time. Air samples for measuring CrVI concentrations require laboratory analysis.

To address the data objectives, data will be collected prior to construction, and then throughout the construction period that involves disturbance of the surface immediately below the synthetic layers of the existing MMC in Area 1. The intended use of the air monitoring data is to 1) obtain empirical pre-construction data to establish the Total PM action level and CrVI background concentration and 2) to measure/monitor Total PM and CrVI during construction to ensure the efficiency of on-going dust-suppression activities such that dust control measures can be supplemented, as appropriate.

The pre-construction air monitoring study will be conducted in March 2014. Construction monitoring will be performed for approximately six (6) months commencing in April 2014.

1.3

DATA QUALITY OBJECTIVES

Data quality objectives (DQOs) are an integrated set of qualitative and quantitative decision statements that define data quality requirements

based on the end use of the data. The EPA has developed a seven-step process (shown in bold italics below) to clarify study objectives, define the appropriate type of data, and specify tolerable levels of potential decision errors that will be used as the basis for establishing the quality and quantity of data needed to support decisions. The DQO process is described in detail in the EPA guidance document, *Guidance on Systematic Planning Using the Data Quality Objectives Process EPA QA/G-4* (February 2006).

1.3.1 *State the Problem*

The problem being addressed is to ensure that representative and accurate real-time particulate and airborne CrVI data are collected to define the pre-construction particulate population reflective of routine background conditions. This data will be used to generate Background Threshold Values (BTVs) that in turn will be used to ensure that the site perimeter and work zones are accurately monitored during construction to control any potential release in a timely manner.

1.3.2 *Identify the Decision*

Is the pre-construction dataset (real-time Total PM and airborne CrVI concentrations) accurate and representative of routine city traffic conditions?

1. Possible Outcome - Collected data shows acceptable variability and expected airborne concentrations.
 - a. No Action.
2. Possible Outcome - Collected pre-construction data shows extreme concentration variability.
 - a. Possible Actions -
 - i. Option - Accept data as representative of urban setting.
 - ii. Option - Confirm the precision estimate between duplicate instruments/ co-located samplers meet the established RPD precision criteria.
 - iii. Option - Review field logs to determine if there were any conditions (unusual traffic, extreme weather, etc.) that could explain the variability.

- iv. Option – Conduct 100% raw data validation.
 - v. Option - Use additional statistical analysis to remove significant outliers and evaluate the influence on data.
3. Possible Outcome - Collected pre-construction data shows unexpected elevated airborne concentrations.
- a. Possible Actions –
 - i. Option - Accept data as representative of urban setting.
 - ii. Option – Confirm the precision estimate between duplicate instruments/ co-located samplers meet the established RPD precision criteria.
 - iii. Option - Review field logs to determine if there were any conditions (unusual traffic, extreme weather, etc.) that could explain the unexpected elevated airborne concentrations.
 - iv. Option – Conduct 100% raw data validation.
 - v. Option - Use additional statistical analysis to remove significant outliers and evaluate the influence on data.

1.3.3 *Identify Inputs to the Decision*

This section summarizes the variables to be measured, the quality assurance/quality control mechanisms in place, measurement quality objectives, data validation and audit results, and statistical analyses to be performed to resolve the decision (Section 1.3.2, above).

Variables to be Measured

Variables to be measured include:

- 24-hour Total PM concentrations;
- 24-hour particulate CrVI concentrations; and
- Observations of ambient conditions and activities in the vicinity of each monitoring station.

Quality Assurance/Quality Control Mechanisms

Quality assurance/quality control (QA/QC) mechanisms are described in detail in Sections 2.5 through 2.7. QA/QC mechanisms include:

- Accuracy, precision, and sensitivity of analysis – review the MQOs are met;
- Representativeness and comparability of field data;
- Sample documentation (including field and laboratory records);
- Maintenance and calibration of field and laboratory equipment;
- Analytical procedures for CrVI that comply with ASTM Standard Test Method D7614-12 Determination of Total Suspended Particulate (TSP) Hexavalent Chromium in Ambient Air Analyzed by Ion Chromatography and Spectrophotometric Measurements; and all of the associated QA/QC requirements of the method (Laboratory SOP is included as Appendix C).
- Review of field and laboratory data by qualified personnel.

Measurement Quality Objectives (MQOs)

MQOs are designed to evaluate and control various phases of the measurement process to ensure that total measurement uncertainty is within a range that will meet the DQO requirements. The MQOs (provided in Table 2) can be defined in terms of the following data quality indicators. A more detailed description of these MQOs and how they will be used to control and assess measurement uncertainty will be described in the following elements of the QAPP.

- Precision – a measure of mutual agreement among individual measurements of the same property usually under prescribed similar conditions. This is the random component of error.

- Bias – the systematic or persistent distortion of a measurement process which causes error in one direction. Bias is determined by estimating the positive and negative deviation from the true value as a percentage of the true value.
- Representativeness – a measure of the degree to which data accurately and precisely represent a characteristic of population, parameter variations at a sampling point, a process condition, or an environmental condition.
- Detectability – the determination of the low range critical value of a characteristic that a method-specific procedure can reliably discern.
- Completeness – a measure of the amount of valid data obtained from a measurement system compared to the amount that was expected to be obtained under correct, normal conditions.
- Comparability – a measure of the level of confidence with which one data set can be compared to another.

Data Validation and Audits

Data validation is discussed in detail in Section 4.1. Audits are discussed in detail in Section 3.0.

Data validation will include the following:

- The laboratory will review and reduce the data internally prior to submitting the data to ERM. Laboratory SOPs for internal data review procedures are included in the laboratory's QAPP.
- Laboratory data will be reviewed by ERM.
- ERM will review precision of the DustTrak 8533 data by assessing results of duplicate monitors at PAM-1.
- Following receipt of the laboratory report, ERM will send the sample group QC package data to Laboratory Data

Consultants, Inc. (LDC), an independent third-party validator, to perform Level II validation, as described in EPA's *Guidance on Environmental Data Verification and Data Validation* (2002). The validation process is described in detail in Section 4.1.

Auditing procedures will include the following:

- Field performance procedure audits will be conducted during pre-construction and construction air monitoring by the ERM QA/QC Manager. Specific attention will be given to field instrumentation QC, sampling methods, data collection, sample preservation, and decontamination to demonstrate compliance with required procedures. Field instrumentation QC procedures will also be verified, including measure of co-located precision for DustTrak 8533.
- Internal laboratory audits should be performed by the Laboratory QA Manager, Laboratory PM, or qualified designee annually. Laboratory systems audits may also be conducted by the ERM QA/QC Officer or qualified designee. This auditor, in conjunction with the Laboratory QA Manager, may conduct the systems startup audit to ensure that all instruments proposed or in use are appropriate for the given methods and functioning properly. Laboratory performance may be audited through PE check samples that contain certified concentrations of target analytes. Audit procedures are described in detail in Section 3.0.

Statistical Analysis

Laboratory statistics will be performed to assure precision, accuracy, and sensitivity of the collected CrVI data. These measures and statistics are discussed in Section 3.4.

1.3.4 *Define the Site Boundaries*

The target media is air at the site perimeter and at off-site locations representative of urban conditions. The site physical boundary is the project property as bounded by the perimeter air monitoring (PAM) stations as shown on Figure 4. Total PM will be provided real-time at

1-minute intervals. Particulate CrVI samples will be collected over a 24-hour interval.

The primary practical constraints include:

- Methods to measure particulate CrVI are limited to analytical laboratory methods. Particulate CrVI cannot be determined real-time in the field.
- Severe weather would create a safety concern and may also damage equipment and influence the monitoring results. Sample collection may be delayed if severe weather is encountered.
- Samples for particulate CrVI must be stored at 0°C or less.
- Monitoring locations will require electric power to operate instruments and sampling pumps.
- Monitoring locations must have safe access for personnel and security for instruments and sampling pumps.

The scale of decision for this site is air at the site property boundaries and urban area vicinity.

1.3.5 *Develop a Decision Rule*

For this project, the decision is whether the data collected meet quality requirements and therefore can be accepted as valid representations of airborne Total PM and particulate CrVI concentrations during pre-construction and during construction. The parameters of interest are the concentrations of Total PM and particulate CrVI in the air shed at the site perimeter and in the vicinity of the project. The decision making scale during pre-construction is a sufficient period of sampling to ensure air samples representative of various ambient conditions in the vicinity of the project are collected. The decision making scale during construction is a rapid response (within 15 minutes) to elevated Total PM concentrations in the immediate, on-site work area at or above a dust action level (the BTV) such that construction generated dust will not migrate off site at concentrations above the BTV.

The expected outcome for pre-construction monitoring is the collection of valid, representative data with which to calculate BTVs. The outcome of

the construction monitoring is the collection of valid, representative data of construction conditions demonstrating that concentrations are at or below the BTVs and are representative of pre-construction conditions. Specifically, the project will:

- Collect Total PM and particulate CrVI data using accurate methods, including data quality review. Ensure that the samples are collected using calibrated equipment. Analyze CrVI concentrations in an EPA-certified laboratory. Ensure that samples are collected over a range of times when construction will occur to account for diurnal cycles in urban sources. Ensure that samples are taken for multiple days to account for daily variation in weather patterns, urban sources, etc. Ensure that appropriate quality assurance/quality control measures are followed to confirm data accuracy and precision; and
- Collect and analyze Total PM and particulate CrVI using the same method during construction as for pre-construction monitoring. Collect real-time Total PM data from locations as close as safely possible to construction activities and from locations on the perimeter of the site to ensure any increases in total PM above the BTV are identified immediately and corrective measures are implemented.

Hypotheses and decision error is discussed in the following section.

1.3.6 *Specify Limits on Decision Errors*

The problem statement is to ensure that representative and accurate real-time particulate and airborne CrVI data is collected to define the pre-construction particulate population reflective of routine background conditions. Collection of acceptable pre-construction total PM and particulate CrVI concentrations is an estimation problem, as defined in the EPA guidance document, *Guidance on Systematic Planning Using the Data Quality Objectives Process EPA QA/G-4* (February 2006). For estimation problems, performance metrics and acceptable levels of uncertainty are used in place of statistical hypothesis testing and decision errors.

For all data collection, data will be required to meet all the field and laboratory procedures and quality control requirements in order to be accepted. For pre-construction, if the data meets all quality goals, it is considered acceptable. For construction, all data must meet the same quality goals for pre-construction in order to be acceptable.

During the construction phase, use of the BTVs to determine whether particulate CrVI concentrations exceed ambient conditions is a decision making problem, as defined in the EPA guidance document, *Guidance on Systematic Planning Using the Data Quality Objectives Process EPA QA/G-4* (February 2006). The hypotheses and associated decision errors are:

- Ho: Total PM concentration is greater than the BTV
 - Type II error (false acceptance): Total PM concentration is identified as greater than the BTV, but is actually less than or equal to the BTV
- Ha: Total PM concentration is less than or equal to the BTV
 - Type I error (false rejection): Total PM concentration is identified as less than or equal to the BTV, but is actually greater than the BTV

Quantitation limits of the error, parameter range, grey region, and acceptable error levels cannot be determined until the BTV for background total PM and particulate CrVI concentrations have been determined.

Collected data must meet all EPA quality requirements and will be validated according to the guidance provided in *EPA Contract Laboratory Program National Functional Guidelines for Inorganic Superfund Data Review* (January 2010) and ASTM Standard Test Method D7614-12. Air monitoring data collected during the pre-construction and construction phases will be validated. Appropriate calibration of equipment during field activities and during laboratory analysis will be performed (see Sections 2.6 and 2.7 and Appendices B and C). Limits on decision errors based on use of the action limit during construction (i.e., addressing false positives) will be established by the project team during development of the Construction Air Monitoring Plan.

1.3.7

Optimize the Sampling Design

Air quality data for establishing pre-construction concentrations for total PM and particulate CrVI will be collected for the range of meteorological conditions present during a 15-day sampling period at three, fixed locations. One location will include a duplicate real-time instrument for Total data and co-located samplers for CrVI (60 CrVI samples collected in total). Air monitoring during construction will be used to assess on-site

and off-site Total PM and particulate CrVI concentrations at six (6), fixed locations (6 CrVI samples per day).

During standard construction hours/days, a minimum of two additional real-time monitors, only, will be placed in the Work Zone immediately adjacent to and upwind of construction intrusive activities. The Work Zone monitors will be set to sound an audible alarm in the event the Total PM action level is exceeded, providing immediate feedback to workers as to when dust levels might require additional controls. Work Zone monitoring will occur on all work days.

1.4 MEASUREMENT PERFORMANCE CRITERIA

The quality of the collected air sampling data must be evaluated and controlled to ensure that data quality is maintained within the established acceptance criteria. Measurement quality objectives for the data apply to both collection of the data (e.g., trip and field blanks) and the analysis procedures (e.g. lab blanks). The measurement objectives for this project are as described in the best practice analytical method included as Appendix C. The analytical method meets specific criteria for precision, bias, representativeness, minimum detection limits, comparability and completeness as shown on Table 2. EPA's definitions for these terms are provided below (EPA 2009).

Precision - a measure of the agreement among repeated measurements of the same constituent, usually under prescribed similar conditions (uncertainty is driven by random error).

Bias - the systematic or persistent distortion of a measurement process which causes error in one direction (uncertainty is driven by systematic error).

Representativeness - a measure of the degree to which an observation or a sample represents the population from which it was drawn.

Detectability - the determination of the low range critical value of a characteristic that a method-specific procedure can reliably discern.

Completeness - a measure of the amount of valid data obtained from a measurement system compared to the amount taken.

Table 2. Measurement Quality Objectives

Compound	Reporting Units	Precision (RPD)*	Bias*	Representativeness	Comparability/ Method Selection	Completeness	Method Detection Limit
Total Particulate Matter	µg/M ³	Duplicate instruments at one location Acceptance criteria: RPD < 40%	NA	Pre-construction – air shed surrounding site vicinity; Construction – air shed at perimeter & surrounding site vicinity	Direct Read Instrument DustTrak 8533; factory and field calibrated	Average daily Total PM concentration measurement for 24-hour sampling day at each location for 15 monitoring days	1.0 µg/M ³
Hexavalent Chromium (CrVI)	ng/ M ³	Co-located sample collection Acceptance criteria: RPD < 20%	25%	Pre-construction – air shed surrounding site vicinity; Construction – air shed at perimeter & surrounding site vicinity	ERG-specific method ERG-MOR-063 based on ASTM Test Method D7614-12	90% of proposed samples Pre-construction = 4 samples per 24-hour sampling day for 15 sampling days. Construction = 6 samples per 24-hour sampling day.	0.0078 ng/ml (0.0036 ng/M ³ based on 21.6 M ³ sample volume)

* = These are estimates. The methods do not state the precision or bias.

RPD = Relative percent difference

ASTM = American Society for Testing and Materials

µg/M³ = Micrograms per cubic meter

ng/M³ = Nanograms per cubic meter

2.0

SPECIAL TRAINING REQUIREMENTS AND CERTIFICATION

Each analyst analyzing samples under this project will have an Initial Demonstration of Capability (IDC) on file for the analysis of Cr(VI) in ambient air at the laboratory that is available for inspection upon request.

The personnel performing the field tasks will be able to demonstrate by training records and documented experience that they can operate, troubleshoot and maintain the equipment and perform QC checks.

2.1

DOCUMENTATION AND RECORDS REQUIREMENTS

Documentation and records anticipated to be generated during the project are listed below, along with their storage location:

Table 3. Records and Storage Locations

Record	Storage Location
<i>Sample Collection and Handling Records</i>	
Daily per-sample field data sheets (including DustTrak 8533 readings) (see Section 2.2. & Appendix B for field sheet contents; info collected will include field equipment maintenance information, see Sections 2.2 & 2.3)	Field (hard copy); Faxed copies scanned and stored weekly in ERM’s office (ERM’s Annapolis, Maryland office) project file (electronic copy).
Field Notebooks	Field (hard copy); Scanned and stored in ERM’s office project file at the conclusion of the field work.
Sample COC sheets	Field (hard copy); Faxed copies weekly scanned and stored in ERM’s office project file
Sample receipt acknowledgement from the laboratory	Electronic copies stored weekly in ERM’s office project file
Field Audit & Corrective Action Reports	Field (hard copy); ERM’s Office project file (electronic copy)
Field SOPs	Field (hard copy); ERM’s Office project file (electronic copy)
<i>Analytical Records</i>	
Laboratory Sample Management Records	ERG (hard copy & electronic)
Test method raw data & reported results	ERG (hard & electronic), ERM project file (electronic)

QA/QC reports (general QC records, MDL info, calibration, etc.)	ERG (hard & electronic), ERM project file (electronic)
Test Method SOP	ERG (hard & electronic), ERM project file (electronic)
DustTrak 8533 data logs	Upload data logs to field computer once per day (electronic), Backup to ERM's Office project within 36 hours of field upload (electronic) and upload to project website during construction within 36 hours of field upload.
<i>Data Assessment Records</i>	
Data validation reports	ERM receives electronic copy from third party data validator & stores electronic copy

All electronic versions/copies of data and reports will be initially stored on ERM's secure server.

Data and reports will be transmitted to HPD, and HPD will supply records to Honeywell, EPA, and MDE as required.

The results of air sampling during construction will be posted to the project website (after validation) per agreement between HPD and EPA and MDE.

The URL for the project website is: <http://harborpointbaltimore.info>.

Data will be retained on file at ERM for a minimum of one year after the cessation of air monitoring, and will be readily available for audits and data verification activities. After one year, hardcopy records and computer backup electronic media will be discarded.

3.0 DATA ACQUISITION

This section describes how the project data will be obtained, including the rationale for the sample design and all field quality controls procedures. The Sampling and Analysis Plans (Appendix A) and the Standard Operation Procedures (SOPs) for field sampling methods are provided in Appendix B. The laboratory SOP is provided in Appendix C.

3.1 SAMPLE COLLECTION PROCEDURES, DESIGN, & SAMPLING TASKS OVERVIEW

Sample collection is based on a judgmental design (rather than probability-based). As described in Section 3, sample collection will occur in two phases – pre-construction and during construction.

3.1.1 Pre-Construction Air Monitoring

Pre-construction air monitoring is intended to provide information on pre-construction air concentrations of Total PM and CrVI in the area of the site. As such, one on-site air monitoring location (PAM-1) and two off-site air monitoring locations (OAM-1 and OAM-2) were selected for sampling, as shown on Figure 3. OAM-1 will be located approximately 0.5 miles west of the site at the Baltimore National Aquarium and will be representative of Baltimore Inner Harbor waterfront background air conditions. OAM - 2 will be located approximately 1.0 miles north of the site at the Old Town monitoring station established by MDE and will be representative of the urban background air conditions. Sampling equipment at OAM-1 and OAM-2 will be secured within a sturdy waterproof case with a locking mechanism. A padlock will be used to secure each case.

Duplicate real-time instruments and co-located CrVI samplers will be placed at PAM-1 to allow for collection of field duplicate data. The siting requirements of 40 CFR Part 58, Appendix E will be used as guidance. Sampler inlets will be placed not less than 2 meters above ground level and have unrestricted air flow for at least 270 degrees around each sampler. The initial monitoring location selection will be verified by EPA and MDE personnel in the field.

Table 4 summarizes the number of samples and analytical methods to be used for the pre-construction and construction sampling. The goal of pre-construction real-time monitoring and sample collection is to collect

samples for 15 consecutive calendar days. In the event that samples cannot be collected (e.g. equipment malfunction, severe weather conditions, etc.), an extra sampling day(s) will be added to the schedule to make up for the collection of lost data and samples to achieve 15 days of sampling. Samples for real-time Total PM and daily average particulate CrVI concentrations will be collected each day at the three monitoring locations and one co-located station for 15 sampling days, yielding 60 primary samples and 30 quality assurance samples for laboratory analysis by laboratory-specific method ERG-MOR-063, which is modified from ASTM Method D7614-12. No potential dust generating activities may occur on the site during pre-construction air monitoring.

A meteorological monitoring station will be sited following EPA siting guidance in EPA-454/B-08-002 Quality Assurance Handbook for Air Pollution Measurement Systems Volume IV: Meteorological Measurements Version 2.0 (Final), March 2008. The wind speed and direction sensors for the meteorological monitoring system will be situated approximately 10 meters above ground, on the Transfer Station Mechanical Room rooftop during the pre-construction and construction air monitoring. The meteorological sensors will be calibrated on-site during installation following the guidance of EPA-454/B-08-002.

Table 4. Pre-construction Monitoring Samples

Sampling Location	Sample Methods	Sample Equipment	Sampling Duration	QA/QC Events
PAM-1	CrVI: Laboratory-specific method ERG-MOR-063	(2) BGI Model PQ-100 pumps with NaHCO ₃ -impregnated Whatman 541 filter cassettes	15 days, 24-hours per primary samples	Check filter for foreign matter, tears, or pinholes Flow rate calibration at beginning and end of sample collection Confirm start and stop flow rates within $\pm 10\%$ Confirm sample operation within time parameters 1 field duplicate: co-located BGI sampler

	Real-time total PM: Equipment-specific method ¹	(2) DustTrak Model 8533 monitors	15 days, 24-hour continuous monitoring	<p>Zero check calibration before first use</p> <p>Clean inlet every 2 weeks</p> <p>Replace internal filters every 2 weeks or sooner if error message noted</p> <p>1 field duplicate: DustTrak DRX 8533 connected to same intake port via a "T" connector</p>
OAM-1	CrVI: Laboratory-specific method ERG-MOR-063	(1) BGI Model PQ-100 pump with NaHCO ₃ -impregnated Whatman 541 filter cassettes	15 days, 24-hours per primary samples	<p>Check filter for foreign matter, tears, or pinholes</p> <p>Flow rate calibration at beginning and end of sample collection</p> <p>Confirm start and stop flow rates within ±10%</p> <p>Confirm sample operation within time parameters</p>
	Real-time total PM: Equipment-specific method ¹	(1) DustTrak DRX 8533 monitor	15 days, 24-hour continuous monitoring	<p>Zero check calibration before first use</p> <p>Clean inlet every 4 weeks</p> <p>Replace internal filters every 2 weeks or sooner if error message noted</p>
OAM-2	CrVI: Laboratory-specific method ERG-MOR-063	(1) BGI Model PQ-100 pump with NaHCO ₃ -impregnated Whatman 541 filter cassettes	15 days, 24-hours per primary sample	<p>Check filter for foreign matter, tears, or pinholes</p> <p>Flow rate calibration at beginning and end of sample collection</p> <p>Confirm start and stop flow rates within ±10%</p> <p>Confirm sample operation within time parameters</p>

	Real-time total PM: Equipment-specific method ¹	(1) DustTrak DRX 8533 monitor	15 days, 24-hour continuous monitoring	Zero check calibration before first use Clean inlet every 4 weeks Replace internal filters every 2 weeks or sooner if error message noted
--	--	-------------------------------	--	---

¹The real-time data is collected continuously including one co-located station, see details provided in the Preconstruction SAP in Appendix A. Daily 24-hour average Total PM concentration results will be used in the statistical analyses as described in Appendix D.

One trip blank will be included in the daily shipments of CrVI filters to the laboratory. Trip blanks are unopened filters.

One field blank will be collected per day of CrVI sample collection. Field blanks will be sent to the field, opened, and then packaged like the primary samples, but not placed on the sampling devices.

One field performance audit will be performed for all three sampling locations.

3.1.2 *Construction Air Monitoring*

During construction, dust levels will be assessed at locations adjacent to intrusive activities (Work Zone sampling), at the perimeter of the site, and off-site. Final monitoring locations will be determined upon completion of the pre-construction sampling event. It is expected that there will be four perimeter monitoring locations at the property boundary of the development (Figure 4, PAM-1 through PAM-4) and two off-site locations (OAM-1 and OAM-2). Note that locations PAM-1, OAM-1, and OAM-2 will also be used during Pre-construction monitoring.

It is anticipated that these perimeter and off-site locations will be operated continuously, 24-hours per day, during “intrusive” construction work days. In addition, each day during construction hours, a minimum of two additional real-time monitors will be placed in the Work Zone immediately adjacent to and upwind of construction intrusive activities. The Work Zone monitors will be set to sound an audible alarm in the event the Total PM action level is exceeded, providing immediate feedback to workers as to when dust levels might require additional controls. Work Zone monitoring will occur on all work days. Table 5 summarizes the number of samples and analytical methods used for construction sampling.

Table 5. Construction Monitoring Samples

Sampling Location	Sample Methods	Sample Equipment	Sampling Duration	QA/QC Events
PAM-1	CrVI: Laboratory -specific method ERG-MOR- 063	(2) BGI Model PQ-100 pump with NaHCO ₃ - impregnated Whatman 541 filter cassettes Co-located	Duration of construction, 24-hours per primary samples	Check filter for foreign matter, tears, or pinholes Flow rate calibration at beginning and end of sample collection Confirm start and stop flow rates within ±10% Confirm sample operation within time parameters
	Real-time total PM: Equipment -specific method	(2) DustTrak Model 8533 Duplicate	Duration of construction, 24-hour continuous monitoring	Zero check calibration before first use Clean inlet every 2 weeks Replace internal filters every 2 weeks or sooner if error message noted
PAM-2	CrVI: Laboratory -specific method ERG-MOR- 063	(1) BGI Model PQ-100 pump with NaHCO ₃ - impregnated Whatman 541 filter cassettes	Duration of construction, 24-hours per primary samples	Check filter for foreign matter, tears, or pinholes Flow rate calibration at beginning and end of sample collection Confirm start and stop flow rates within ±10% Confirm sample operation within time parameters
	Real-time total PM: Equipment -specific method	(1) DustTrak DRX 8533	Duration of construction, 24-hour continuous monitoring	Zero check calibration before first use Clean inlet every 4 weeks Replace internal filters every 2 weeks or sooner if error message noted
PAM-3	CrVI: Laboratory -specific method ERG-MOR- 063	(1) BGI Model PQ-100 pump with NaHCO ₃ - impregnated Whatman 541 filter cassettes	Duration of construction, 24-hours per primary samples	Check filter for foreign matter, tears, or pinholes Flow rate calibration at beginning and end of sample collection Confirm start and stop

Sampling Location	Sample Methods	Sample Equipment	Sampling Duration	QA/QC Events
				flow rates within $\pm 10\%$ Confirm sample operation within time parameters
	Real-time total PM: Equipment -specific method	(1) DustTrak Model 8533	Duration of construction, 24-hour continuous monitoring	Zero check calibration before first use Clean inlet every 2 weeks Replace internal filters every 2 weeks or sooner if error message noted
PAM-4	CrVI: Laboratory -specific method ERG-MOR-063	(1) BGI Model PQ-100 pump with NaHCO ₃ -impregnated Whatman 541 filter cassettes	Duration of construction, 24-hours per primary samples	Check filter for foreign matter, tears, or pinholes Flow rate calibration at beginning and end of sample collection Confirm start and stop flow rates within $\pm 10\%$ Confirm sample operation within time parameters
	Real-time total PM: Equipment -specific method	(1) DustTrak Model 8533	Duration of construction, 24-hour continuous monitoring	Zero check calibration before first use Clean inlet every 2 weeks Replace internal filters every 2 weeks or sooner if error message noted
OAM-1	CrVI: Laboratory -specific method ERG-MOR-063	(1) BGI Model PQ-100 pump with NaHCO ₃ -impregnated Whatman 541 filter cassettes	Duration of construction, 24-hours per primary samples	Check filter for foreign matter, tears, or pinholes Flow rate calibration at beginning and end of sample collection Confirm start and stop flow rates within $\pm 10\%$ Confirm sample operation within time parameters
	Real-time total PM:	(1) DustTrak Model 8533	Duration of construction,	Zero check calibration before first use

Sampling Location	Sample Methods	Sample Equipment	Sampling Duration	QA/QC Events
	Equipment-specific method		24-hour continuous monitoring	Clean inlet every 2 weeks Replace internal filters every 2 weeks or sooner if error message noted
OAM-2	CrVI: Laboratory-specific method ERG-MOR-063	(1) BGI Model PQ-100 pump with NaHCO ₃ -impregnated Whatman 541 filter cassettes	Duration of construction, 24-hours per primary samples	Check filter for foreign matter, tears, or pinholes Flow rate calibration at beginning and end of sample collection Confirm start and stop flow rates within ±10% Confirm sample operation within time parameters
	Real-time total PM: Equipment-specific method	(1) DustTrak Model 8533	Duration of construction, 24-hour continuous monitoring	Zero check calibration before first use Clean inlet every 2 weeks Replace internal filters every 2 weeks or sooner if error message noted

Each perimeter and off-site air monitoring location will be sited in accordance with EPA monitor siting guidelines established in 40 CFR Part 58, Appendix E, to provide representative data for the area. This guidance ensures monitoring locations and equipment will be sited, to the extent possible, away from trees, buildings, roadways, or other obstacles that may cause undue influence on the measured concentrations. Sampler inlets will be placed not less than 2 meters above ground level and have unrestricted air flow for at least 270 degrees around each sampler. The monitoring location selection will be verified by EPA and MDE personnel in the field.

A meteorological monitoring station will be sited following EPA siting guidance in EPA-454/B-08-002 *Quality Assurance Handbook for Air Pollution Measurement Systems Volume IV: Meteorological Measurements Version 2.0 (Final)*, March 2008. The wind speed and direction sensors for the meteorological monitoring system will be situated approximately 10 meters above ground, on the Transfer Station Mechanical Room rooftop during the pre-construction and construction air monitoring. The meteorological sensors will be calibrated on-site during installation following the guidance of EPA-454/B-08-002.

3.2

SAMPLING PROCEDURES AND REQUIREMENTS

Details of sample collection procedures are provided in the Sampling and Analysis Plans (Appendix A). Sample start time, end time, beginning and ending flow rate (see Section 4.6), and total sample volumes will be recorded on the field forms (Appendix B) along with any other pertinent information regarding sample collection.

In addition to the field forms, field information will also be recorded in field notebooks that are sequentially pre-numbered; the field notebooks will be bound, have a water-resistant cover, and be assigned to individual field personnel for the duration of field activities. Entries will be as detailed and as descriptive as practical so that a particular situation can be recalled without relying solely on the sampler's memory. Field log entries will be dated and signed. Information entered in the field notebook will include, at a minimum, the following items:

- Project name and number;
- Dates and times of entries;
- Weather conditions;
- Names of personnel performing the activities;
- A description of sample locations, including sample name and type;
- Field instrument calibration information;
- Field instrument readings; and
- Health and safety information.

Information recorded in the field notebook should be neat, legible, completed in dark, permanent ink, and signed and dated by the person completing the entry.

Copies of the field notebook will be provided to the PM, and the data will be summarized for reporting purposes and retained in the appropriate project file.

Field notebooks will be stored in ERM's project file when not in use.

Corrections to field documentation will be made by striking out the incorrect entry, entering the corrected value or text, and dating and initialing the document; the original entry will remain visible.

3.3 *SAMPLING HANDLING, CUSTODY PROCEDURES, AND DOCUMENTATION*

CrVI samples will be stored in an on-site freezer and shipped to the laboratory daily during pre-construction monitoring and twice per week during construction monitoring. CrVI samples have a holding time of 10 days, providing they are kept frozen. Sample coolers will be refreshed with ice packs as necessary to ensure a temperature of less than 0°C is maintained until receipt by the laboratory. Samples will be stored in the laboratory freezer until extraction and sample analysis immediately thereafter.

CrVI samples are collected on specific, laboratory-prepared filters that are loaded by the laboratory into cassettes. In the field, the cassettes are loaded into the sample pump for collection of primary samples. Filters will be considered invalid if any of the following occur:

- Filter has been dropped or contaminated with any foreign matter (such as dirt, finger marks, ink, liquids, etc.);
- Filter with tears or pinholes;
- The start and stop flow rates differ more than $\pm 10\%$; or
- Filter sample operates less than 23 hours or more than 25 hours.

The sample date and time collected, project name and number, and unique sampling number associated with the filter will be recorded on the sample label. CrVI samples will be placed in a cooler with ice packs immediately after removing filter cassettes from the sample pump, as CrVI samples must arrive at the lab at 0°C.

The COC of the physical sample and its corresponding documentation will be maintained throughout the handling of the sample. All samples must be identified, labeled, logged in a COC form, and recorded in the field notebook as a part of the procedure to ensure the integrity of the resulting data. Information required on the COC form includes the following:

- Project name, location, and number;
- Name of ERM PM;
- Sampler name and signature;
- Location and time of sampling;
- Total volume of air that passed through the filter, **including both the calculated total volume and the total volume reported by the BGI PQ-100 sampler;**
- Unique sampling number associated with the filter;
- Sample type and matrix;
- Requested analytical parameters or methods;
- Laboratory name and contact information;
- Signature of person relinquishing samples;
- Date and time of relinquishing;
- Special instructions, if any;
- Signature of receiver and date and time samples received (completed by laboratory upon receipt).

The record of the physical sample (location and time of sampling, total volume of air that passed through each filter) will be related to the analytical results through accurate accounting of the sample custody. Sample custody applies to both field and laboratory operations. Analytical requests will be identified on the form. The information (for each sample) provided on the COC form will duplicate the information provided on the sample label of each sample container. A carbon copy of the COC form completed by the field team will be submitted to the ERM QA Manager. The original and carbon copy COC form will be placed in protective plastic and will be taped to the inside lid of the cooler containing samples before transport to the laboratory. The COC forms will be retained in the ERM project job files by the QA Manager.

Sampling personnel will be responsible for the care and custody of the samples from the time they are collected until they are transferred to another individual. A sample is under an individual's custody if one of the following criteria is met:

- It is in the sampler's possession.
- It is in the sampler's view after being in possession.
- It is in the sampler's possession and secured to prevent tampering.
- It is in a designated secure area.

Sampling personnel will complete the COC form for each sample shipment. When transferring custody, the individuals relinquishing and receiving samples will sign, date, and note the time of the exchange on the record. The COC record will be completed using waterproof ink. Corrections will be made by drawing a single line through the error and initialing and dating the correction. Information will not be erased or rendered unreadable.

When the samples arrive at the laboratory, the laboratory personnel receiving the sample cooler will evaluate the integrity of the samples and sign the COC form. The laboratory will assign work order numbers to the samples for use in its internal tracking system. Damaged sample containers, sample labeling discrepancies between sample container labels and the COC form, and analytical request discrepancies will be noted on the COC form. The laboratory will contact the ERM FM or ERM Quality Manager by sending the COCs and the sample non-conformance report electronically within 24 hours of sample receipt. The laboratory will also provide a sample acknowledgment to ERM indicating field sample identification, laboratory identification number, and analytical testing logged for each sample. ERM will review this information for correctness within 24 hours of receipt and provide feedback to the laboratory. The status of a sample can be checked at any time by referring to the laboratory numbers on the COC form and the laboratory work order numbers in the notebook. Both the laboratory and unique sampling numbers will be cited when the analytical results are reported. The laboratory will send the carbon copy of the COC form and the analytical data package to the PM.

Standard Operating Procedures (SOPs) and data collection forms have been developed for sample custody, sample labeling, analysis requests,

and shipping and tracking procedures. Field SOPs are included in Appendix B. Analytical laboratory sample custody procedures are included in the laboratory SOP (Appendix C), which identify the roles of both the sample custodian and the laboratory coordinator.

3.4 ANALYTICAL METHOD REQUIREMENTS

Analytical methods and over-all analytical quality requirements for the laboratory are provided in Table 2. The laboratory-specific Method ERG-MOR-063 (modified ASTM Method D7614-12) is provided in Appendix C. The required laboratory turn-around time (TAT) will be three (3) business days from receipt of samples during the pre-construction and the construction phases unless written approval is received from EPA and MDE to extend the TAT to 10 business days.

3.5 FIELD QUALITY CONTROL REQUIREMENTS

Field blank filters in sample cassettes will be sent to the field, opened, and re-packaged as with the sample filter cassettes but not exposed to the air on a sampling device, and returned to the laboratories along with the primary samples according to the schedule shown in Tables 4 and 5. Blank filters will be provided by the laboratories from the same lot as the filters provided for sample collection. Additionally, a trip blank will be included in each sample set (2 per week, one in each shipment to the laboratory). A trip blank is shipped to the field and back to the laboratory, but never opened. All filters will be maintained at a temperature of less than 0°C from the time of shipment from the laboratory until the time of analysis, except during field sampling.

3.6 FIELD INSTRUMENT/EQUIPMENT CALIBRATION AND MAINTENANCE REQUIREMENTS

Maintenance and calibration of field instruments are included in the field Standard Operating Procedures in Appendix B. Sampling equipment will be maintained according to the manufacturer's specifications. A summary of the daily field calibration procedures is provided in Table 6 and a summary of field equipment maintenance procedures is provided in Table 7. Calibration and maintenance procedures for collection of samples for particulate CrVI and for Total PM are detailed below.

Table 6. Field Calibration, Testing, and Inspection

Field Equipment	Calibration Activity	Testing Activity	Inspection Activity	Frequency	Acceptance Criteria
BGI Model PQ-100	Pump flow rate	One point calibration using BGI TetraCal	Initial daily flow check Start/stop flow rates	Beginning and end of each sample collection period	Initial flow rates $\pm 4\%$ Start and stop flow rates $\pm 10\%$ Flow rate at 15 L/min
DustTrak DRX 8533	Zero instrument Pump flow rate	1-point check with zero filter One point calibration using BIOS Defender 510-H	Zero value Initial daily flow check Start/stop flow rates	Once per day Once per day	2 liters per minute, $\pm 5\%$ ± 0.001 milligrams per cubic meter

Table 7. Field Equipment Maintenance, Testing and Inspection

Field Equipment	Parameter	Maintenance Activities	Inspection Activity	Frequency	Acceptance Criteria
BGI Model PQ-100	Pump flow rate	Replace diaphragms, valves, and bearings after 5000 hours of use	Check pump cumulative time	Beginning of each week	Less than 4,500 cumulative hours
DustTrak DRX 8533	Zero instrument Clean instrument	1-point check with zero filter Clean inlet and internal filters Factory cleaning and calibration	Zero value Confirm that no error indicators are present on instrument screen Confirm with rental agency that factory cleaning has occurred	Once per day Check instrument screen once per day; clean once every two weeks Beginning of project	±0.001 milligrams per cubic meter Confirm maintenance schedule in field notebook

CrVI: Air samples will be collected using BGI Model PQ-100 or equivalent samplers. Sampling will be performed at 15 L/min during the sampling period. Sampling flow rates will be checked at the beginning and end of each sampling period, using BGI TetraCal flow standard and flow rates recorded on the field sampling form (form included in Appendix B). If the initial daily flow check varies from the pre-set sampling flow rate by more than 4 percent, a full recalibration will be performed. The total volume reported by the BGI PQ-100 will be provided on the field forms with the data reports. For QC comparison, the average flow rate reported by the BGI PQ-100 will be multiplied by the exact duration of time the sample was being collected in order that the total volume can also be calculated for each sample. Note that the instrument is designed to maintain a steady flow rate. If the beginning and ending flow rates vary by more than 10%, the filter is invalidated. Calibration records and the individual air volumes per filter, including all volume calculations will be documented and provided with data reports.

The BGI Model PQ-100 instruction manual is provided in the Pre-construction and Construction SAPs found in Appendix A.

DustTrak DRX 8533: The DustTrak Model 8533 monitors Total PM concentrations and stores 1-minute averages on an internal data logger. The manufacturer lists daily maintenance and calibration procedures that will be followed in the field. In addition, other maintenance and calibration procedures that will be used are as follows:

- Before each use: perform a zero check according to manual instructions.
- Manufacturer instructions recommend cleaning the inlet after every 350 hr. if total dust concentrations are at 1 mg/M³. As a practical matter in the field, the inlet will be cleaned every two (2) weeks and the cleaning date and time recorded in the field notebook.
- Manufacturer instructions recommend replacing internal filters every 350 hr. if total dust concentrations are at 1 mg/M³ or when indicated by the main screen filter error indicator. As a practical matter in the field, if no error message has been noted, the inlet will be cleaned every two (2) weeks and the cleaning date and time recorded in the field notebook.

Because the DustTrak Model 8533 will be operated in the Total PM mode rather than size-specific classifications, the factory-set photometric calibration factor (PCF) of 1.0 and size correction factor (SCF) of 1.0 will be used. As recommended by the manufacturer, the Ambient Air calibration factor will be selected to represent outdoor ambient dust. The DustTrak Model 8533 instruction manual is provided in the Pre-construction and Construction SAPs, Appendix A.

Laboratory instrument/equipment calibration and maintenance requirements are provided in Appendix C.

3.7

LABORATORY QUALITY CONTROL REQUIREMENTS

Laboratory records are defined as all written, recorded, and electronic documentation necessary to reconstruct all laboratory activities that produce data and include all information relating to the laboratory's equipment, analytical test methods, and related activities.

The laboratory will retain copies of all sample, sample QC and calibration runs, quantitation reports, injection logs, preparation summary sheets, corrective action reports, and summary information in a central file location for 5 years from the date of analysis. Electronic copies of raw data should also be retained by the laboratory for 5 years from the date of analysis.

Specific laboratory instrument calibration procedures for various instruments are described in detail in the method-specific procedures and laboratory SOPs for the analytical laboratory selected, as provided in Appendix C.

3.8 DATA MANAGEMENT REQUIREMENTS

This section describes the data management process and methods to ensure data integrity from data production in the field to final use and retention. All data will be reviewed and verified for accuracy by the ERM QA/QC Officer and Field Manager (FM). The ERM FM will ensure that the field and technical data obtained for the project will provide the end user with acceptable data. All field and technical data shall be reviewed by the ERM QA/QC Officer, to ensure that the final data is accurate prior to the inclusion in the project report. The field data sheets, log books, COC forms, and DustTrak data are reviewed and submitted (faxed, electronic, or hard copy) by the ERM FM to the ERM QA/QC Officer daily.

The analytical data processing procedure is presented on Figure 5 and summarized as follows:

1. Samples are sent to the laboratory under COC.
2. The laboratory enters the sample information into their tracking system and performs the analysis.
3. The laboratory electronically submits raw data, sample results, and their QA information to ERM and to an independent third party validator, who in turn performs Level II validation, as described in EPA's *Guidance on Environmental Data Verification and Data Validation* (2002).
4. The third party validator electronically submits their validation report to ERM.

5. ERM reviews the data validation report, and, if acceptable, stores all data into the project files. If unacceptable, ERM may request re-analysis of the data by the laboratory. Under this condition, the ERM PM will bring this result to the attention of EPA and MDE and request their concurrence of ERM's recommendation of whether or not to perform the re-analysis.
6. Once the ERM QA/QC Officer completes the accuracy review, the ERM FM, or their designee, then stores the validated information electronically into ERM's project files and uploads the summary tables to the project website.

Real-time data processing is summarized as follows:

1. The field data sheets (real-time Total PM) and real-time instrument data logs are submitted (faxed, electronic, or hard copy) by field personnel to the ERM PM weekly. The ERM PM, or their designee checks all metadata for accuracy, then stores the information electronically into ERM's project files.
2. ERM submits the field data sheets and real-time instrument data logs to the third party validator.
3. The third party validator electronically submits their validation report to ERM.

Real-time Total PM concentration data will be provided as hourly averages based on one (1) minute frequency data collection. The daily average real-time Total PM concentration data will be used to calculate the dust action level, i.e., the background threshold value (BTV).

4.0 ASSESSMENTS

4.1 FIELD DATA REVIEW

The process of reviewing field data will involve evaluating field records for consistency and completeness assuring that each sample result is fully supported by accurate metadata, reviewing QC and calibration information, summarizing deviations and determining their impact on data quality, summarizing the samples collected, and summary of the review in the project report.

Field data (provided to the ERM PM by fax, electronically or hard copy) will be scanned at least weekly and stored electronically as part of the project database maintained by ERM

4.1.1 *Sampling Program Design Execution*

Sample collection records (provided to ERM PM by fax, electronically or hard copy) will be reviewed weekly by the ERM QA/QC Officer/PM or qualified designee to ensure that samples have been collected according to the sampling design. Items to be reviewed include the types and numbers of samples collected, sampling locations and frequencies, and measurement parameters of interest. Deviations must be reported to ERM's PM immediately. Under this condition, the ERM PM will bring this result to the attention of EPA and MDE and request their concurrence of ERM's recommendation of whether or not the identified deviation requires any additional attention.

4.1.2 *Sample Collection Procedures*

Sample collection procedures will be reviewed by the ERM FM and the ERM QA/QC Officer to ensure that the appropriate procedures have been followed. Items to be reviewed include sampling methods and equipment, sample type, time, location and sample preservation requirements. Deviations must be reported to the ERM PM immediately. The PM will determine whether the samples meet the field quality control requirements specified in Section 4.5.1. Under this condition, the ERM PM will bring this result to the attention of EPA and MDE and request their concurrence of ERM's recommendation of whether or not the identified deviation requires any additional attention.

4.1.3 *Sample Handling*

Sample handling procedures will be reviewed by the ERM FM and the ERM QA/QC Officer to ensure that the appropriate procedures have been followed. Items to be reviewed include sample labeling, COC documentation, sample preservation and holding times, sample packaging, and shipment. Deviations from established procedures must be reported to the PM immediately. Under this condition, the ERM PM will bring this result to the attention of EPA and MDE and request their concurrence of ERM's recommendation of whether or not the identified deviation requires any additional attention.

4.1.4 *Quantitative Field Data*

The volume calculations performed in the field will be verified by the ERM FM and the ERM QA/QC Officer, along with the sample collection and handling procedures noted above.

4.1.5 *Field and Technical Data Reduction*

Field and analytical data will be summarized in tables as appropriate. ERM will perform a 100% check of all data presented on data summary tables.

4.2 **LABORATORY DATA**

This section describes the data review, reduction, and verification processes for laboratory data, as well as who is responsible for executing each process.

4.2.1 *Laboratory Data Review and Reduction*

The laboratory will review and reduce the data internally in accordance with its SOP (Appendix C) and established internal procedures prior to submitting the data to the ERM FM. The ERG SOP contains all quality control requirements, as shown in the SOP Tables 24-1 and 24-2. Laboratory SOPs for internal data review procedures are to be maintained electronically in the project files. Specifically, the laboratory will review the data package to ensure the following:

- Sample preparation information is correct and complete;
- Holding times have been met;

- Analytical information is complete and was generated within acceptable criteria;
- Any discrepancies/corrective actions identified during sample login, preparation or analysis have been addressed and documented;
- The appropriate SOPs have been followed;
- QC samples were within established control limits;
- Analytical requirements have been met (e.g., the correct analytical procedures were used as defined by the COC); and
- Documentation is complete and any QC issues are fully explained in a detailed case narrative.

An authorized laboratory employee must sign the data package to indicate the data have been reviewed.

Data will be reduced in the laboratory following method protocols and reported in standard formats. The data will be peer-reviewed by a qualified analyst before it is released to ERM. The review will be documented with a standard checklist that has been initialed and dated by the peer reviewer. Reporting requirements for analytical data pertain only to the final data report to be submitted to ERM.

4.2.2 *Laboratory Data Review and Validation*

Following receipt of the laboratory report, ERM will send the report (including raw data and all QA/QC information) to the designated third-party validator. The third party will perform Level II validation, as described in EPA's *Guidance on Environmental Data Verification and Data Validation* (2002). Level II validation will include 40% raw data re-calculation.

4.3 *AUDITS OF DATA QUALITY*

A performance audit is defined as a review of the existing procedures and analytical data (sample and QA) to determine the accuracy of the total measurement systems, or a component of the system. The analysis of a project-specific laboratory Performance Evaluation (PE) sample is the primary method for a performance audit of the laboratory. An equivalent

evaluation sample audit method is difficult to produce in the field; therefore, procedure audits will be performed to assess the accuracy and consistent application of field SOPs.

4.3.1 *Performance Audits*

4.3.1.1 *Field Performance Audits*

Performance audits of field activities consist of procedure audits that may be conducted by the PM or qualified designee. During a procedure audit, the field auditor observes and reviews actual procedures to verify conformance with written field procedures as well as sampling and analysis protocols. Specific attention is given to sampling, data collection, sample preservation, decontamination, and disposal of waste to demonstrate compliance with required procedures. Field instrumentation QC procedures are also verified. The field auditor meets with key field staff members to evaluate the field program and determine if changes are necessary to improve data quality. One field performance audit will be performed during the pre-construction phase of the project.

Audit items are tied to the tasks defined in the field procedures, as well as in the sampling and analysis protocols, rather than restricted to a specific list. The field auditor verbally reports the results of each audit to the PM within one working day to transmit any significant problems with the field QA program. Any non-conformance identified during the audit will be reported immediately to the PM and remedied as soon as possible. A written report will be provided to key personnel and placed in the project file within 10 working days of each audit. This report should include a field audit checklist, documentation of on-site meetings, findings, and program revisions.

4.3.1.2 *Laboratory Performance Audits*

In a performance audit, a PE sample is submitted to the laboratory and analyzed for the purpose of evaluating the performance of the measurement or analytical procedures used by the laboratory. The PE sample consists of some type of environmental matrix (e.g., air, soil, water) which contains a known amount of a particular analyte(s). The PE sample result will be submitted to EPA and MDE prior to initiating the pre-construction monitoring.

Review of PE sample data will be performed by the third-party reviewer and includes verifying the following:

- Sample analysis was completed following the correct methodology;
- Correct identification and quantitation of sample analytes;
- Accurate and complete reporting of data to meet project specifications; and
- Instruments are operating within established precision and accuracy control limits.

Results that do not fall into the certified limits of acceptability may indicate a laboratory performance problem and will trigger immediate corrective actions. All particulate CrVI samples will be analyzed by ERG for this project.

4.3.2 *System Audits*

The ERM QA/QC Officer or qualified designee may conduct a laboratory systems audit. This auditor, in conjunction with the Laboratory QA Manager, may conduct the systems startup audit to ensure that all instruments proposed or in use are appropriate for the given methods and functioning properly. Additional external audits will be performed as needed. Internal laboratory audits should be performed by the Laboratory QA Manager, Laboratory PM, or qualified designee annually.

During internal and external audits, the auditor will observe and review laboratory procedures and analytical results to ensure that they conform to the operating procedures and reporting requirements. Prior to the laboratory audit, the auditor will prepare a list of items and procedures to be audited. Audit items may be tied to the analyses of the samples in progress rather than be restricted to a specific list. Internal systems audits will include a review of the following:

- Sample custody and tracking procedures;
- Calibration procedures and documentation;
- Completeness of data forms, notebooks, and other data reporting documents;
- Compliance with laboratory SOPs;
- Data storage, filing, and record-keeping procedures;
- QC procedures, criteria, and documentation;

- Operating conditions of equipment and facilities;
- Employee training records; and
- Laboratory information and management system procedures and security.

External systems audits will include a review of the previous items plus a review of laboratory internal assessment SOPs and laboratory internal assessment documentation. The auditor will meet with key staff members to evaluate the program and determine if corrective actions are necessary to improve the data quality.

The auditor will submit a report in writing to the ERM QA/QC Officer or PM within five (5) working days of the audit. The report will include the documentation of on-site meetings, findings, and proposed revisions. A written assessment of the laboratory with any suggested changes in procedures will be provided to the laboratory. Follow-up audits will be conducted if warranted by the audit findings. If changes in the systems are necessary, the Laboratory PM or designee will make the changes. Written confirmation within 10 days will document any corrective actions the laboratory has implemented to meet requirements of the measurement system. The letter should be directed to the ERM PM or QA/QC Officer's attention.

After the ERM PM has been notified (following the initial systems audit) that the laboratory systems are all satisfactory, QC measures will be implemented. After implementation of the plan, all procedures will be monitored internally by the laboratory to facilitate compliance with the requirements. Any significant problems within the system will be verbally reported immediately to the QA/QC Officer. Verbal notification will be followed by a written report within 10 working days from completion of the audit and/or the resolution of the change. Written reports should be retained in the laboratory permanent files, as well as in ERM's project file.

4.4 SURVEILLANCE OF OPERATIONS

The results of monitoring will be posted to the project-dedicated website within approximately 24 hours, as practicable, of real-time collection or receipt of validated laboratory results. In this manner the public will have ready access to monitoring results. The website will also post any response actions deemed necessary due to the air monitoring results.

The Developer's representative is responsible for all necessary notifications to both the MDE and EPA representatives. The Developer's representative on site will ensure both EPA and MDE's representatives are apprised of the air monitoring activities and results on a daily basis. In this manner, the agencies can assess the need to notify the public of the air monitoring results and related response actions, as appropriate.

4.5 ASSESSMENT OF DATA QUALITY

4.5.1 *Field Data Quality*

Data quality assessment criteria for field measurements include the following parameters:

Precision– Precision of field procedures will be assessed through the collection of field duplicate real-time data and co-located samples (Section 2.0). Field duplicate data will be collected for Total PM by use of second DustTrak monitor (duplicate), which will be connected to the same inlet. Co-located samples of particulate CrVI will be collected at a frequency of one per day. If the relative percent differences (RPDs) for field duplicate data or co-located sample results are within acceptance criteria, the original result should be used. However, if the RPDs are not within acceptance criteria, the more conservative result should be used. Additional actions to assess and improve precision may include collecting duplicate total particulate matter samples for gravimetric analysis for comparison. The DustTrak Field instrument accuracy and precision will be confirmed using the QA/QC actions described in Table 4.

Accuracy – Accuracy in the field is a measure of how close the value is to the true value and will be assessed by the Laboratory Control Sample, also known as the Method Spike.

Completeness – Field completeness is a measure of the number of valid field measurements obtained relative to the total number of field measurements. The percent of completeness for field data can be expressed by the following formula:

$$\text{Percent Completeness} = (V/T) \times 100$$

Where:

V = Number of valid data points

T = Total number of data points

Field completeness is based on the number of samples or field tests planned and the actual number collected or performed. The completeness objective for field measurements is 90 percent.

Representativeness – Representativeness in the field will be ensured by following standard procedures during data collection. The ERM PM will monitor the sampling program to ensure that field activities are being conducted consistently according to the procedures outlined in the QAPP and the SAP. Additionally, field duplicates will reflect representativeness by measuring sample homogeneity and precision.

Comparability – Measures to ensure comparability of field data include field personnel reviewing the QAPP and the SAP. ERM's FM and/or QA Manager will routinely verify that proper field activity procedures are being followed. To facilitate comparability of field data, ERM field staff will only utilize the approved SAPs and Field SOPs.

Sensitivity – Sensitivity is the capability of a method or instrument to discriminate between measurement responses representing different levels of a variable of interest, or to detect or reliably measure low levels of a variable of interest. Field sensitivity basically refers to the smallest value or change in value a field instrument can reliably measure above background noise. For the pre-construction and construction phases of this project, this concept applies to measurement of Total PM. The sensitivity objectives for the DustTrak include the following specifications:

- Concentration Range = 0.001 to 150 mg/m³
- Resolution = ±0.1% of reading or 0.001 mg/m³, whichever is greater
- Flow Accuracy = ±5% of factory set point

4.5.2

Laboratory Data Reduction

Field and analytical data will be summarized in tables as appropriate and discussed in the text of the data report.

The quality of laboratory data will be evaluated based on precision, accuracy, representativeness, completeness, and comparability of the data generated by each type of analysis. These data assessment parameters are described in the following sections. The specific analytical criteria including reporting limits and control limits for QC results are provided in Appendix C.

Blank samples are used to determine contamination arising from principally four sources: the environment from which the sample was collected/analyzed, the reagents used in the analysis, the apparatus used, and the operator/analyst performing the analysis. Three types of blanks will be implemented in the in this monitoring program:

- **Field blanks** - Field blank cassettes will be included for CrVI samples yielding one filter cassette blank per day that samples are collected. Blank filter cassettes will be sent to the field, opened, but not placed on the sampling devices, and then packaged like the actual samples. Field blank cassettes will be returned to the laboratories in the same shipment as the primary samples.
- **Trip blanks** - Trip blank cassettes will be included for CrVI samples yielding one filter cassette blank per sample shipment. The trip blank is an un-opened, un-handled filter cassette.
- **Lab blanks** - Laboratory SOP for the ASTM Standard Test Method D7614-12 (Determination of Total Suspended Particulate (TSP) Hexavalent Chromium in Ambient Air Analyzed by Ion Chromatography and Spectrophotometric Measurements is included with this QAPP in Appendix C. This SOP includes procedures and criteria for lab blanks, spiked samples, and duplicate analyses.

4.6

QUALITATIVE AND QUANTITATIVE COMPARISONS TO ACCEPTANCE CRITERIA

4.6.1

Precision

Precision is a measure of random error, and describes the degree to which repeated measurements are similar to one another. It measures the agreement or reproducibility among individual measurements. Precision will be measured through the use of field duplicate samples. Duplicate samples are ideally expected to contain similar chemical concentrations; therefore, it is generally assumed that any variability in results is introduced by inherent field heterogeneity, sampling, handling, or laboratory procedures.

Precision will be calculated as the RPD as follows:

$$\% RPD_i = \frac{|O_i - D_i|}{(O_i + D_i)/2} \times 100\%$$

where:

$\% RPD_i$ = Relative percent difference for compound i

O_i = Value of compound i in original sample

D_i = Value of compound i in duplicate sample

The resultant RPD will be compared to acceptance criteria and deviations from specified limits reported. If the laboratory objective criteria are not met, the laboratory will supply a justification of why the acceptability limits were exceeded and implement the appropriate corrective actions.

LDC, the third-party data quality reviewer will assess field and laboratory RPDs and deviations from the specified limits will be noted and the effect on reported data commented upon by LDC, as described in Section 4.0. The data review will be provided to the ERM FM, who will take corrective actions described in Section 4.0.

4.6.2

Accuracy

Accuracy is the amount of agreement between a measured value and the true value. It will be measured as the percent recovery of blank spike samples and performance evaluation (PE) samples.

Accuracy shall be calculated as percent recovery of spiked analytes as follows:

$$\%R_i = (Y_i \div X_i) \times 100\%$$

where:

$\%R_i$ = percent recovery for compound i

Y_i = measured spike concentration in sample i
(sample concentration with the spike - original sample concentration)

X_i = actual spike amount in sample i

The resultant percent recoveries will be compared to acceptance criteria (described in Section 4.0) and deviations from specified limits will be reported. If the objective criteria are not met, the laboratory will supply a justification of why the acceptability limits were exceeded and implement the appropriate corrective actions.

LDC, the third-party data quality reviewer will assess laboratory %R and deviations from the specified limits will be noted and the effect on reported data commented upon by LDC, as described in Section 4.0. The data review will be provided to the ERM FM, who will take corrective actions described in Section 4.0.

4.6.3

Representativeness

Representativeness is a qualitative parameter that expresses the degree to which sample data accurately and precisely represent a characteristic of a population, parameter variations at a sampling point, or an environmental condition. Representativeness of the environmental conditions at the time of sampling is achieved by selecting sampling locations, methods, and times so that the data describe the site conditions that the project seeks to evaluate. Representative samples will also be ensured through following proper protocols for sample handling (storage, preservation, packaging, custody, and transportation), sample documentation, and laboratory sample handling and documentation procedures.

4.6.4 *Comparability*

Comparability is a qualitative parameter expressing the confidence with which one data set can be compared to another. The comparability goal is achieved by maintaining consistency in sampling conditions, selection of sampling procedures, sample preservation methods, and analytical methods.

4.6.5 *Completeness*

Completeness for usable data is defined as the percentage of usable data out of the total amount of planned data. The closer the numbers are; the more complete the measurement system. The target goal for completeness is 90 percent for all data. Completeness will be calculated as follows:

$$\%C = \frac{A}{I} \times 100\%$$

where:

$\%C$ = Percent completeness (analytical)

A = Number of usable sample results reported (all results not rejected)

I = Total number of results reported

Non-valid data (i.e., data qualified as “R” rejected) will be identified during the data review and the reasons for rejection explained in the data review report.

4.6.6 *Sensitivity (Method Detection Limit)*

Sensitivity is the capability of a method or instrument to discriminate between measurement responses representing different levels of a variable of interest, or to detect or reliably measure low levels of a variable of interest. Sensitivity defines the method detection limit (MDL) as the minimum concentration of a substance that can be measured and reported with 99 percent confidence that the concentration is greater than zero. The MDL for particulate CrVI is provided Section 4.0.

The MDL is determined every year according to the procedure in 40 CFR, Part 136, Appendix B. A standard is spiked onto at least seven prepared filters at a concentration one to five times the estimated detection limit.

These filters are extracted and analyzed according to the method outlined. The MDL is calculated as follows:

$$\text{MDL} = (t) \times (\text{SD})$$

where:

t = Student's t value for a 99% confidence level and a standard deviation estimate with $n - 1$ degrees for freedom [$t = 3.14$ for seven replicates]

SD = Standard deviation of the replicate analysis

The laboratory will maintain current records of DL studies for each instrument, and will have established reasonable accuracy (lower control limits should be 10 percent or greater) and precision goals for the analytical method utilized. The laboratory should perform DL verification studies at least annually for each method, as stipulated by National Environmental Laboratory Accreditation Conference. The concentration of the standards used to determine the DLs should be no more than five times the expected DL value. Historical DL studies, accuracy, and precision limit control charts should be retained in the laboratory archives for five (5) years.

4.7 *INTERIM ASSESSMENTS OF DATA QUALITY*

Evaluation of field and laboratory QC data and/or audits conducted for field operations and/or laboratory operations may indicate the need for a corrective action. Problems with analytical QC data will be addressed by the laboratory QC officer. Problems arising during field operations, however, will be addressed by the Technical Lead through communication of the identified problem and proposed corrective action to the ERM Project Manager. The Project Manager and Technical Lead will discuss the appropriate actions with the MDE and EPA representatives to obtain concurrence, and then relay this information to the field personnel for implementation. The field personnel will then report back to the ERM Project Manager upon successful implementation of the corrective act.

5 *REVIEW, EVALUATION OF USABILITY AND REPORTING REQUIREMENTS*

5.1 *DATA VERIFICATION AND VALIDATION TARGETS AND METHODS*

All data will be verified by a review of the completeness and accuracy of each result's metadata. Field operations will be fully documented, reviewed, and audited. All CrVI data will undergo Level II third party data validation. The precision of the DustTrak particulate data will be determined by daily duplicate results.

The quality of field and laboratory data will be evaluated based on precision, accuracy, representativeness, completeness, and comparability of the data generated by each type of analysis. These data assessment parameters are described in the following sections. The specific analytical criteria, including reporting limits and control limits for QC results, are provided in Appendix C.

5.2 QUANTITATIVE AND QUALITATIVE EVALUATIONS OF USABILITY

When the results of the measurements have been obtained, the ERM Project Manager, QA Manager and Technical Lead will determine whether the project QA/QC goals have been achieved. Whether the overall project QA/QC goals have been met will be assessed by review of the analytical data quality assessment reports generated using data verification/validation. All laboratory results will be reviewed by the ERM FM to verify that the data package is complete. The completeness check will include a brief screening of six basic elements that should be included in each data package, including:

- Verification that sample numbers and analyses match the chain-of-custody request.
- Are all analyses that are requested on the Chain-of-Custody and any change orders present in the data package?
- Does the data package include a copy of the Chain-of-Custody forms?
- Has the laboratory placed any data qualifier flags on the analytical results?

- Does the laboratory's case narrative identify problems, including an explanation of flagged data?
- Does the data package include reports for all QA/QC samples (see Table 5)?
- Based on any missing information and/or gross quality control exceedence, should the laboratory perform additional analytical work on the samples before holding times have expired or the leftover sample is discarded?

The completeness, correctness, and conformance/compliance of the data will be verified and validated against the method, procedural, or contractual requirements. Guidance for data verification/validation is provided in EPA's *Guidance on Environmental Data Verification and Data Validation* (EPA 2002b) and EPA's National Functional Guidelines (EPA 1999; EPA 2004). Laboratory data will be validated in accordance with ASTM Standard Test Method D7614-12 and the EPA document *EPA Contract Laboratory Program (CLP) National Functional Guidelines for Inorganic Data Review*, October 2004. One hundred percent of laboratory data will be validated by Laboratory Data Consultants, Inc., a third-party data reviewer. A Level II data review will be conducted, which consists of the following elements:

- Verification that sample numbers and analyses match the chain-of-custody request.
- Verification that sample preservation and holding times are met.
- Verification that instrument performance checks were performed and acceptable.
- Verification that calibrations were performed at the appropriate frequency and met method criteria.
- Verification that field, trip, and laboratory blanks were performed at the proper frequency and that no analytes were present in the blanks.
- Verification that field and laboratory duplicates, matrix spikes, and laboratory control samples were run at the proper frequency and that control limits were met.

- Verify that internal standards results were acceptable.
- Verification that project reporting limits have been achieved.

Data review and verification will be performed for 100 percent of the data. In addition, the third-party reviewer will re-calculate 40% of the raw data, which will include the following additional elements:

- Initial Calibration Review: Review initial calibration calculations for agreement with summary form results, linearity, and method-specified minimum requirements;
- Continuing Calibration Review: Review continuing calibration calculations for agreement with summary form results, linearity, and method-specified minimum requirements;
- Laboratory Control Sample (Method Spike) Review: Review internal standard responses to ensure that minimum and maximum method-specified requirements are met and the correct internal standard has been assigned to target compounds and surrogates;
- Target Compound Identification Review: Review target compounds identified in project and QC samples and ensure that calculated concentrations and identifications are accurate; and

If deemed appropriate according to the EPA National Functional Guidelines, Contract Laboratory Program data qualifiers will be applied to indicate potential concerns regarding data quality. Data qualifiers that may be applied to project data based on data validation are listed below:

- U: The analyte was analyzed, but not detected above the reported LOD or the LOQ was raised to the concentration found in the sample due to blank contamination;
- J: The analyte was positively identified; the associated numerical value is the approximate concentration of the analyte in the sample or result/LOQ is estimated due to quality control issues identified during the verification or validation process;
- N: The analysis indicates the presence of an analyte for which there is presumptive evidence to make a “tentative identification;”

- NJ: The analysis indicates the presence of an analyte that has been “tentatively identified” and the associated numerical value represents its approximate concentration;
- UJ: The analyte was not detected above the reported LOQ; however, the LOQ is approximate and may or may not represent the actual LOQ necessary to accurately and precisely measure the analyte in the sample; and
- R: The sample result or LOQ is rejected due to serious deficiencies in the ability to analyze the sample and meet QC criteria. The presence or absence of the analyte cannot be verified.

Memoranda documenting the results for all data reviews will be prepared for each analytical data package or sample groups. Completed data review memoranda will be submitted to the ERM Project Manager and copies will be retained in the project file.

5.3

POTENTIAL LIMITATIONS ON DATA INTERPRETATION

Field and laboratory data generated for this project will be reviewed to ensure that all project objectives are met. If any non-conformances are found in the field procedures, sample collection procedures, field documentation procedures, laboratory analytical and documentation procedures, and data evaluation and quality review procedures, the impact of those non-conformances on the overall project objectives will be assessed. Appropriate actions, including resampling and reanalysis, may be recommended to the project team so that the project objectives can be accomplished.

Evaluation of field and laboratory QC data and/or audits conducted for field operations and/or laboratory operations may indicate the need for a corrective action. Problems with analytical QC data will be addressed by the laboratory QC officer. Problems arising during field operations, however, will be addressed by the Technical Lead through communication of the identified problem and a proposed corrective action to the ERM Project Manager. The ERM Project Manager will discuss the appropriate actions with the HPD representative and EPA and MDE Project Coordinators to obtain concurrence, and then relay this information to the field personnel for implementation. The field personnel will then report back to the ERM Project Manager upon successful implementation of the corrective action.

5.4 *RECONCILIATION WITH PROJECT REQUIREMENTS*

The project management team, QA Coordinator, and sampling and analytical team members are responsible for ensuring that all measurement procedures are followed as specified and that measurement data meet the prescribed acceptance criteria. Prompt action must be taken to correct any problem that may arise.

5.4.1 *Conduct Preliminary Data Review*

A preliminary data review will be performed to uncover potential limitations to using the data, to reveal outliers, and generally to explore the basic structure of the data. The first step is to review the quality assurance reports. The second step is to calculate the BTVs, generate graphical presentations of the data, and review these summary statistics and graphs.

5.4.2 *Draw Conclusions from the Data*

If the sampling design and statistical tests conducted during the final reporting process show results that meet acceptance criteria, it can be assumed that the network design and the uncertainty of the data are acceptable. This conclusion can then be reported to EPA.

5.5 *REPORTS TO MANAGEMENT*

This subsection describes the types of reports that may be produced for the project. The types of reports that may be produced include daily data summary tables, event logs, data quality assessment reports, PE and audit reports, and the pre-construction summary report.

5.5.1 *Daily Data Summary Tables*

Daily data summary tables with hourly airborne Total PM concentrations for each PAM and OAM station, hourly wind speed, wind direction and daily rainfall will be prepared by the field staff.

5.5.2 *Event Logs*

When applicable, event logs will be generated to identify nonconforming situations and corrective actions taken. Corrective actions to remedy a nonconforming situation in the field can be defined by the ERM field personnel or the ERM QA/QC Officer or PM. A description of the

required action will be documented in an event log. Corrective actions must be approved verbally by the QA/QC Officer prior to implementation. Upon implementation of the corrective action, the ERM QA/QC Officer or PM will be provided with the completed event log, which becomes part of the project file. Copies of completed event log will also be provided in the data summary reports.

5.5.3 *Data Quality Assessment Reports*

The field staff will report to the ERM PM, or a qualified designee on the progress of each phase of field work and any QA/QC issues associated with field activities. Additionally, the laboratory will maintain detailed procedures for record-keeping and reporting to support the validity of all analytical work. The Laboratory QA Manager will provide the ERM QA/QC Officer certification documentation, including audit reports, upon request. A data quality assessment will be included in the Pre-Construction Report to ensure that the DQOs were met.

5.5.4 *Performance Evaluation and Audit Reports*

As discussed in Section 3.1, laboratory PEs and audits may be performed during the course of the project. If performed, the ERM QA/QC Officer will prepare a report summarizing the results.

5.5.5 *Summary Data Reports*

The summary data report titled, "Harbor Point Development Pre-Construction Air Monitoring Report", will be produced by ERM and will include, electronically, the complete laboratory data packages, and all underlying metadata.

Figures

Figure 1—Project Organization Chart

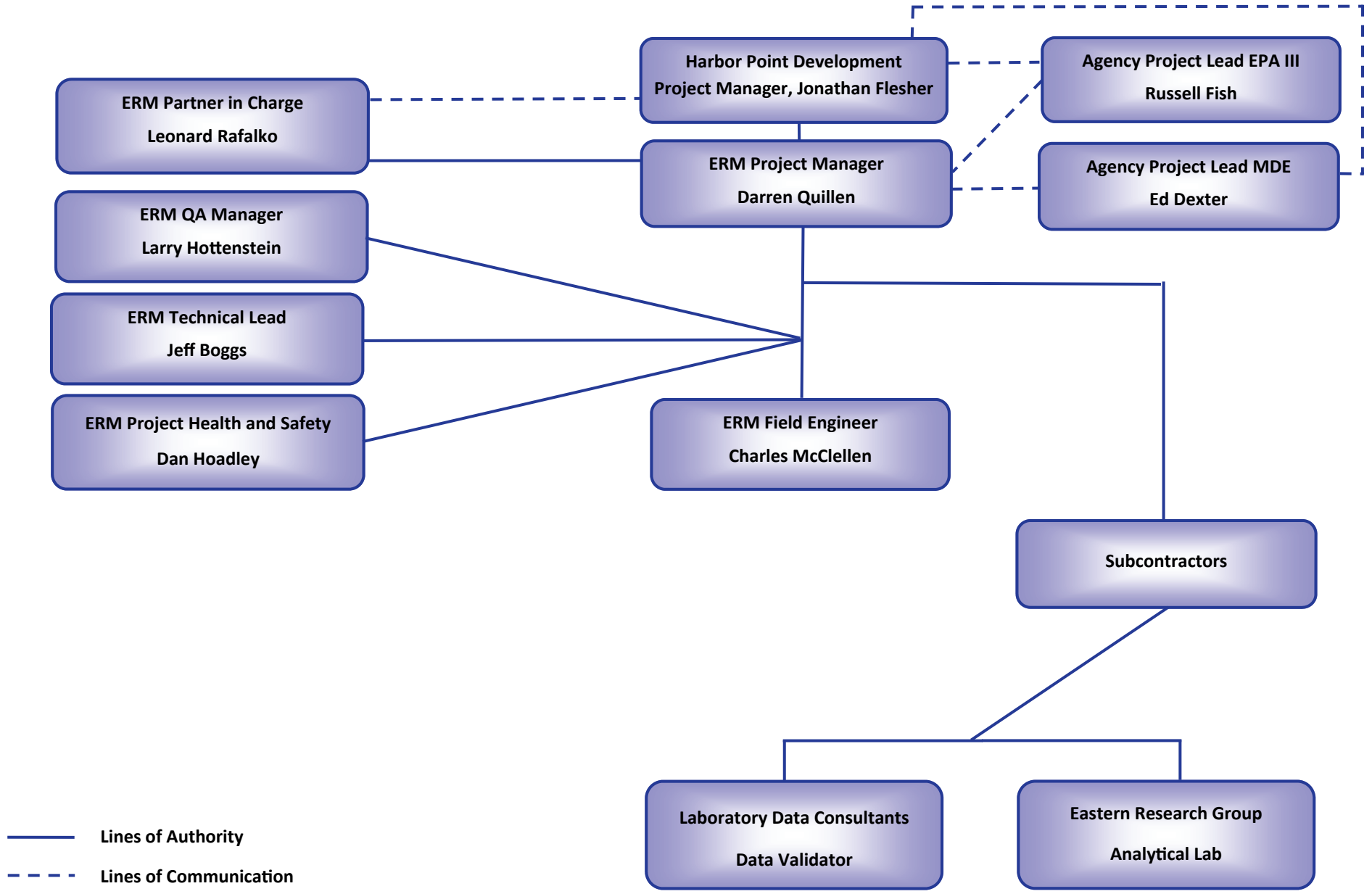

**Figure 2
Project Area**

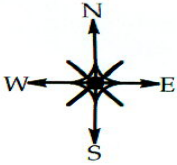
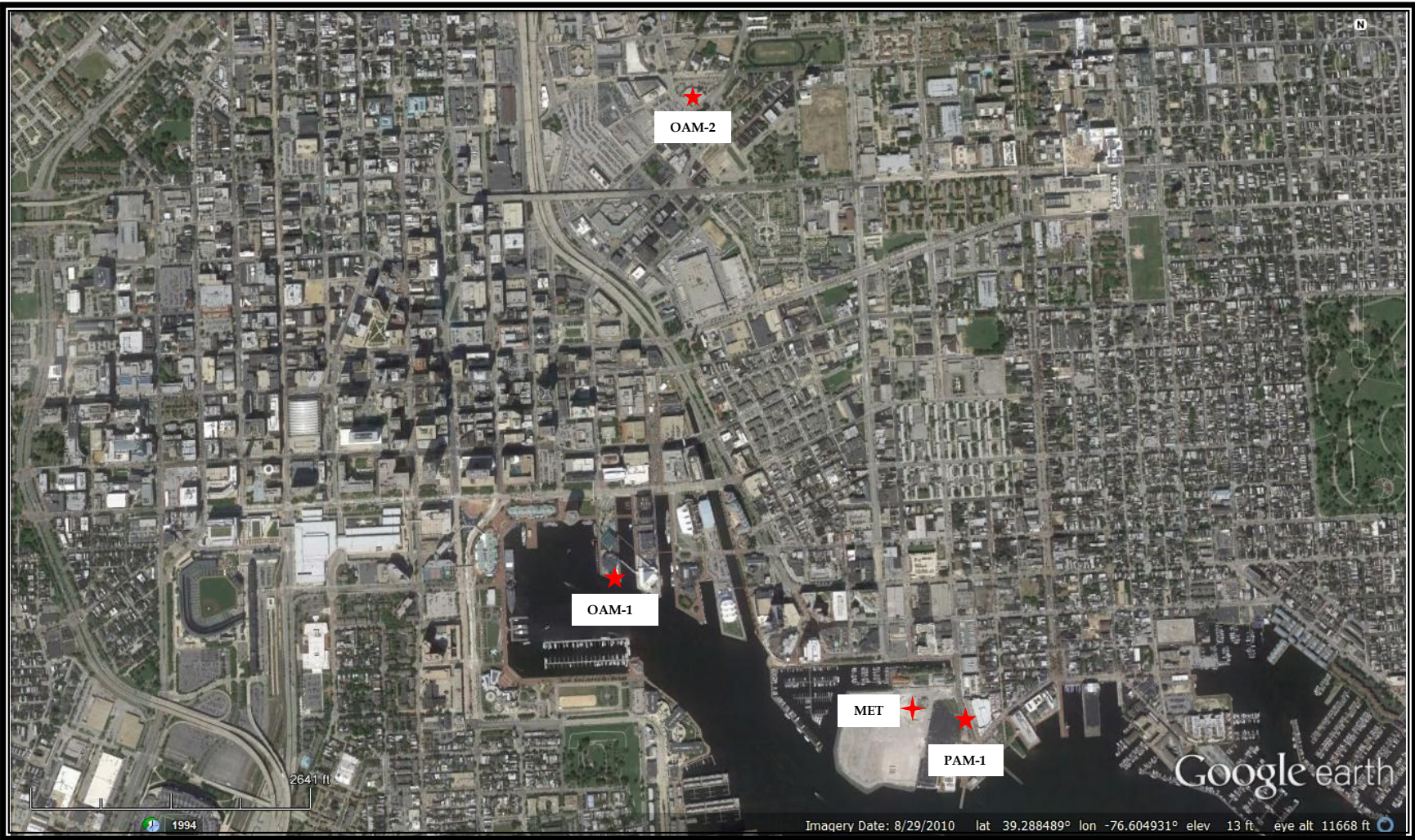
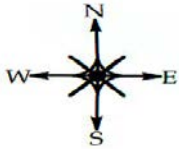
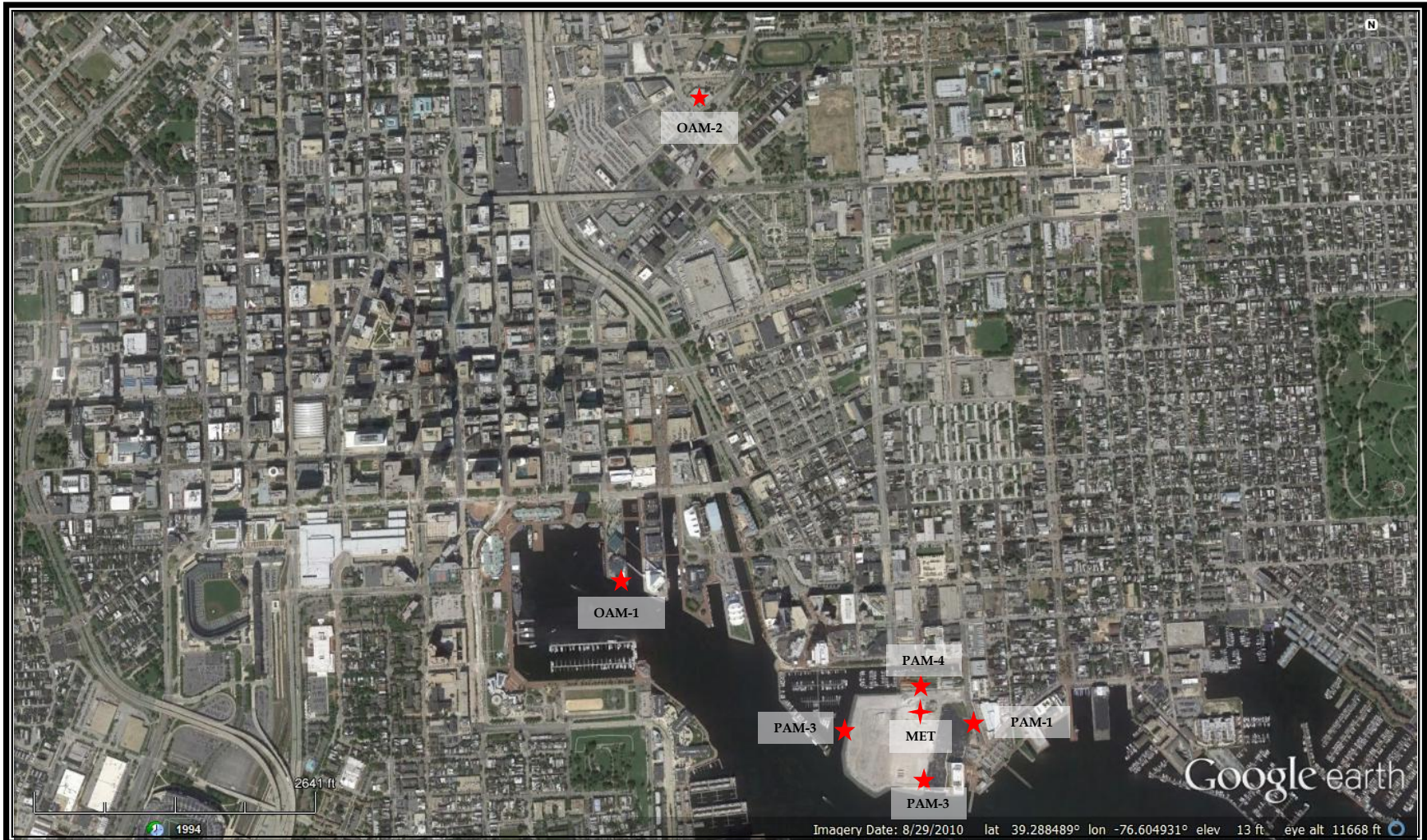
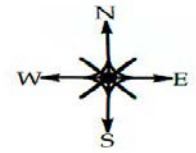

Figure 3
Pre-construction Air Monitoring Locations
Harbor Point
Baltimore, Maryland



MET - Meteorological Station
PAM - Perimeter Air Monitor
OAM - Off-site Air Monitor
1 - Baltimore National Aquarium
2 - MDE's Old Town Station

Figure 4
Construction Air Monitoring Locations
Harbor Point
Baltimore, Maryland



- MET - Meteorological Station
- PAM - Perimeter Air Monitor
- OAM - Off-site Air Monitor
 - 1 - Baltimore National Aquarium
 - 2 - MDE's Old Town Station

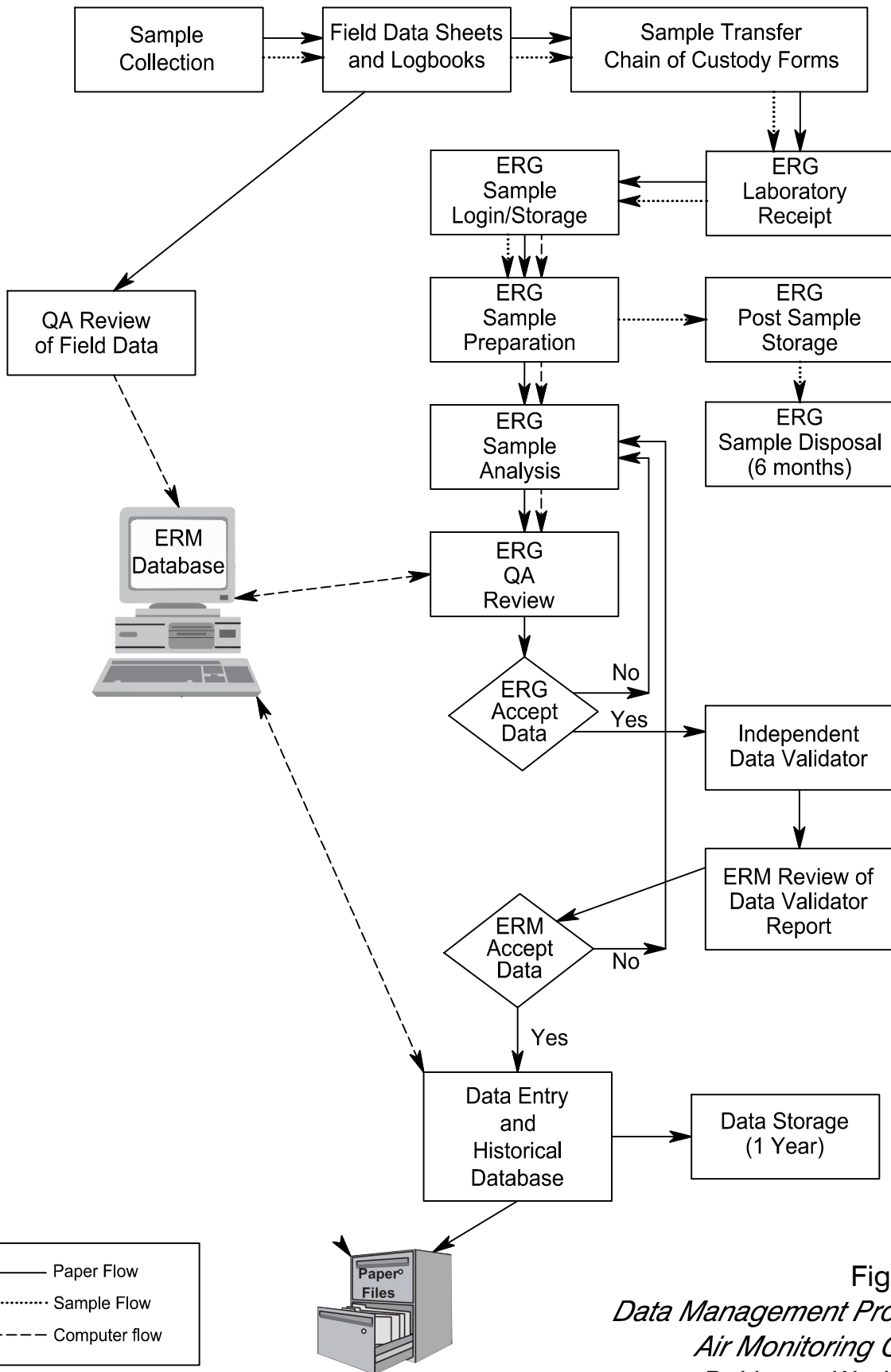

Figure 5
Data Management Process
Air Monitoring QAAP
Baltimore Works site
Baltimore, Maryland

Appendix A
Sample & Analysis Plans

Pre-construction Sampling and
Analysis Plan
Area 1, Phase 1 Development

Baltimore Works Site
Baltimore, Maryland

March 2014

By:
Environmental Resources Management Inc.
Harbor Point Development LLC

For:
U.S. Environmental Protection Agency - Region III
Maryland Department of the Environment

Pre-construction Sampling and Analysis Plan for

Area 1, Phase 1 Development

Baltimore Works Site

Harbor Point Development, LLC

1300 Thames Street, Suite 110

Baltimore, Maryland 21231

Date: 27 February 2014

Harbor Point Development, LLC, Project Manager: Jonathan Flesher

Environmental Resources Management, Inc., QA Officer: Larry Hottenstein

For EPA use:

Approved by EPA Project
Manager:

Date:

Expedited Review? **G** Yes **G** No

Received by QA Office:

Date:

Reviewed by:

Date:

Approved:

Date

Region 3 Quality Assurance
Manager

TABLE OF CONTENTS

1.0	INTRODUCTION	1
1.1	SITE NAME	1
1.2	SITE LOCATION	2
1.3	RESPONSIBLE AGENT	2
1.4	PROJECT ORGANIZATION	2
1.5	STATEMENT OF THE SPECIFIC PROBLEM	5
2.0	BACKGROUND	6
2.1	SAMPLING AREA DESCRIPTION	6
2.2	OPERATIONAL HISTORY	6
2.3	PREVIOUS INVESTIGATIONS/REGULATORY INVOLVEMENT	7
2.4	ENVIRONMENTAL AND/OR HUMAN IMPACT	7
3.0	PROJECT DATA QUALITY OBJECTIVES	8
3.1	PROJECT TASK AND PROBLEM DEFINITION	8
3.2	DATA QUALITY OBJECTIVES (DQOS)	8
3.3	DATA QUALITY INDICATORS (DQIS)	9
3.4	DATA REVIEW AND VALIDATION	13
3.4.1	Field Data Review	13
3.4.2	Laboratory Data Review and Validation	14
3.5	DATA MANAGEMENT	15
3.6	ASSESSMENT OVERSIGHT	16
4.0	SAMPLING RATIONALE	17
4.1	TOTAL PARTICULATE MATTER MONITORING	17
4.2	HEXAVALENT CHROMIUM SAMPLING	17

5.0	REQUEST FOR ANALYSES	19
5.1	ANALYSES NARRATIVE	19
5.2	ANALYTICAL LABORATORY	19
6.0	FIELD METHODS AND PROCEDURES	20
6.1.1	<i>List of Equipment Needed</i>	20
6.1.2	<i>Calibration of Field Equipment</i>	21
6.2	AIR	21
6.2.1	<i>Total Particulate Matter</i>	21
6.2.2	<i>Hexavalent Chromium Sampling</i>	22
7.0	SAMPLE CONTAINERS, PRESERVATION AND STORAGE	23
8.0	DISPOSAL OF RESIDUAL MATERIALS	25
9.0	SAMPLE DOCUMENTATION AND SHIPMENT	26
9.1	FIELD NOTES	26
9.1.1	<i>Field Logbooks</i>	26
9.1.2	<i>Photographs</i>	27
9.2	LABELING	27
9.3	SAMPLE CHAIN-OF-CUSTODY FORMS AND CUSTODY SEALS	28
9.4	PACKAGING AND SHIPMENT	28
10.0	QUALITY CONTROL	30
10.1	FIELD QUALITY CONTROL SAMPLES	30
10.1.1	<i>Assessment of Field Contamination (Blanks)</i>	30
10.1.2	<i>Assessment of Field Variability</i>	31
10.2	LABORATORY QUALITY CONTROL SAMPLES	31
11.0	FIELD VARIANCES	32
12.0	FIELD HEALTH AND SAFETY PROCEDURES	33

LIST OF TABLES

- 1 PROJECT ORGANIZATION***
- 2 SUMMARY OF QUALITY CONTROL PROCEDURES FOR CRVI ANALYSIS***

LIST OF FIGURES

- 1 SITE VICINITY***
- 2 MONITORING STATION LOCATIONS***

APPENDICES

- A STATION SITING INFORMATION***

1.0

INTRODUCTION

The Harbor Point, Area 1, Phase 1 Development will occur at a location (the site) that was formerly a chromium chemical manufacturing facility. The historical manufacturing processes at the site resulted in chromium impacts to soil and groundwater. Hexavalent chromium (CrVI) is considered by the EPA to be a known human carcinogen by the inhalation route of exposure (EPA 2013). Inhalation of CrVI dusts is also associated with non-cancer toxicity.

Phase 1 of the development project consists of the Exelon Tower and Trading Floor Garage, the Central Plaza Garage, modifications to the existing Transfer Station, general site development (streets, sidewalks, etc.) and utilities, foundations, roadways, and other related site development elements and remedy restorations for development.

Because of the dynamic nature of dust-disturbing activities during construction, providing real time information on concentration levels of particulates to project personnel during construction is necessary in order that dust-generating activities on site can be appropriately controlled.

Real-time instrumentation is available to measure ambient concentrations of total particulate matter (Total PM), but such instrumentation is not available for measuring CrVI concentrations in real-time. Therefore, air samples for measuring CrVI concentrations require laboratory analysis.

The goal of the pre-construction air monitoring and sampling is to collect data for 15 consecutive calendar days at three (3) monitoring station locations. In the event that samples cannot be collected (e.g. equipment malfunction, severe weather conditions, etc.), an extra sampling day(s) will be added to the schedule to make up for the lost sampling time so that data has been collected for a total of 15 calendar days. The intended use of the pre-construction air monitoring data is to obtain empirical data to establish the Total PM action level and CrVI background concentration to be utilized during construction.

1.1

SITE NAME

Baltimore Works

1.2 *SITE LOCATION*

The site is located on a peninsula on the northeast shore of the Patapsco River of the Inner Harbor, in the Fells Point section of Baltimore City, Maryland (Figure 1).

1.3 *RESPONSIBLE AGENT*

Environmental Resources Management, Inc. (ERM) will be responsible for the implementation and conduct of the air monitoring program for this project. ERM is a leading global provider of environmental, health, safety, risk, social consulting services and sustainability related services with more than 5,000 people in over 40 countries and territories working out of more than 150 offices. ERM's Annapolis, MD office will provide the field and project management staff and the Irvine, CA office will provide quality control/assurance personnel for the project.

1.4 *PROJECT ORGANIZATION*

Table 1. Project Organization

Name	Title/Role	Organizational Affiliation	Responsibilities
Jonathan Flesher	Project Manager	HPD	<ul style="list-style-type: none">• Oversees all project activities.• Directs the scope of work to the ERM PM.• Reviews and approves all documents and coordinate transmittal of documents to appropriate parties for review.• Communicates with stakeholders regarding project activities.
Lenny Rafalko	Partner-in-Charge	ERM	<ul style="list-style-type: none">• Oversees entire program for ERM.• Reviews all final deliverables and invoices.• Seeks HPD feedback on performance of project managers.• Addresses program-level issues.

Name	Title/Role	Organizational Affiliation	Responsibilities
Darren Quillen	Project Manager	ERM	<ul style="list-style-type: none"> • Reports to ERM Partner-in-Charge (Leonard Rafalko) and HPD (Jonathan Flesher) • Directs ERM Field Manager and subcontractors. • Communicates questions or issues to Agency leads (Ed Dexter, MDE and Russell Fish, EPA) • Ensures that assigned staff has been trained in SOP implementation. • Ensures that all key decisions and project deliverables are subjected to independent technical review by qualified personnel within the time frame of the project schedule.
Larry Hottenstein	QA/QC Manager	ERM	<ul style="list-style-type: none"> • Monitor subcontractor (CrVI analysis) for compliance with both project and data quality requirements records, costs, and progress of the work and re-plan and re-schedule work tasks as appropriate. • Ensure and document that QC checks on field equipment are performed according to schedule and meet acceptance criteria, and the QA/QC • Resolves field QA/QC issues. • Audit sample preservation, handling, transport, and custody procedures throughout the project. • Review and approve all data reduction and reporting procedures for inclusion in deliverables. • Review and respond to audit assessment findings, determine the root cause for any nonconformance, confer with the ERM PM and Partner in Charge on the steps to be taken for correction, and ensure that procedures are modified to reflect the corrective action and are distributed to all field personnel, including subcontractors. • Report QA and any procedural problems to the ERM PM and Partner in Charge

Name	Title/Role	Organizational Affiliation	Responsibilities
Jeff Boggs	Technical Lead/ Field Manager	ERM	<ul style="list-style-type: none"> • Provide technical support to ERM's PM, QA Manager, and Field Technician as needed. • Reports to ERM PM. • Prepares and implements this SAP and deliverables. • Ensures data collection activities are consistent with approved SAP, SOP and QAPP requirements. • Oversees evaluation of data received from the laboratory in accordance with the project requirements. • Prepares or oversees the preparation of portions of the reports that summarize data results and present conclusions.
Charles McClellan	Field Technician	ERM	<ul style="list-style-type: none"> • Performs monitoring and collects samples according to project approved QAPP, SOPs and this SAP. • Reports to ERM Field Manager (if Field Manager not available, report to ERM PM). • Communicates any problems or deviations from project plans to ERM Field Manager. • Ensures that all data collection and handling activities comply with applicable SOPs, including audits conducted in the presence of Agency personnel. • Prepares and maintains field forms, notebooks, and equipment. • Implements technical procedures applicable to tasks. • Inspects and accepts supplies and consumables. • Coordinates and schedules sample shipment to analytical laboratory to meet holding times and analytical procedure specifications.

Name	Title/Role	Organizational Affiliation	Responsibilities
Julie Swift	Project Manager	ERG	<ul style="list-style-type: none"> • Reviews and implements analytical laboratory elements of this SAP with regards to the CrVI analysis. • Manages analytical chemists to complete the sample analyses selected in this SAP, according to the approved methods. • Monitors, reviews, and documents the quality of all analytical chemistry work performed by ERG under this SAP. • Oversees management of analytical data. • Transmits completed data packages to the ERM Quality Manager • Promptly informs the ERM's Quality Manager of any laboratory analytical problems, data quality issues, or delays in sample analysis. • Promptly responds to any data quality issues identified through the independent data validation process.

1.5

STATEMENT OF THE SPECIFIC PROBLEM

The problem being addressed is to ensure that representative and accurate real-time particulate and airborne CrVI data are collected to define the pre-construction particulate population reflective of routine background conditions. This data will be used to generate Background Threshold Values (BTVs) that in turn will be used to ensure that the site perimeter and work zones are accurately monitored during construction to control any potential release in a timely manner.

2.0

BACKGROUND

Area 1 is the principal site of Honeywell's (formerly AlliedSignal) Baltimore Works Facility which included chromium processing production and support buildings on an area that covered approximately 14 acres. The principal contaminant of concern in Area 1 is hexavalent chromium (CrVI). An Environmental Remediation System (ERS) is maintained and operated by Honeywell International Inc. (Honeywell) to contain CrVI-impacted groundwater in Area 1 and control the potential for human exposure to affected soil.

The site development must not interfere with the efficacy of the corrective measures or Honeywell's ability to comply with the performance standards defined in the Consent Decree between Honeywell, the U.S. Department of Justice, U.S. Environmental Protection Agency and the Maryland Department of the Environment.

2.1

SAMPLING AREA DESCRIPTION

The site occupies approximately 14 acres in an urban area. The site is bordered on the north by the Living Classrooms, on the west by a marina, on the south by the Northwest Branch of the Patapsco River, and on the east by the Thames Street Wharf office Building. The specific location of the site is shown in Figure 1.

The original buildings and infrastructure associated with the Baltimore Works chromium plant have been removed from the site. The ERS is operated by Honeywell and consists of a Multimedia cap (MMC), Hydraulic barrier, Head Maintenance System (HMS), a groundwater storage and transfer system, and Outboard Embankment. A two-story building, the Transfer Station, is currently in use in support of the HMS.

2.2

OPERATIONAL HISTORY

There are no operations at the site other than those associated with the ERS. Those operations were initiated in 2002 following completion of corrective actions. Approximately 60,000 gallons of chromium contaminated groundwater are withdrawn annually by the HMS, temporarily stored in the Transfer Station tank room and transported off-site for treatment at Environmental Quality of Pennsylvania.

2.3 *PREVIOUS INVESTIGATIONS/REGULATORY INVOLVEMENT*

The sites has been the subject of numerous Agency-led investigations dating back to 1989, leading to the approved corrective measures implementation and are included in the administrative record.

2.4 *ENVIRONMENTAL AND/OR HUMAN IMPACT*

The primary concern is the potential for particulates containing CrVI to be distributed on-site and off-site during the period of construction that involves the disturbance of contaminated materials below the MMC. CrVI is considered by the EPA to be a known human carcinogen by the inhalation route of exposure (EPA 2013). Inhalation of CrVI dusts is also associated with non-cancer toxicity.

3.0 *PROJECT DATA QUALITY OBJECTIVES*

This section formulates the problem that the sampling needs to solve and determines the level of data quality necessary to address the problem. Specifically, data quality objectives and indicators are developed to ensure that the collected data will be of sufficient quality to be able to adequately address the problem.

3.1 *PROJECT TASK AND PROBLEM DEFINITION*

The purpose of the pre-construction air monitoring study is to collect representative and accurate real-time airborne total PM and CrVI laboratory analytical data to define the pre-construction particulate population reflective of background urban conditions.

3.2 *DATA QUALITY OBJECTIVES (DQOS)*

Data quality objectives (DQOs) are quantitative and qualitative statements that define study objectives, the appropriate type of data, specify tolerable levels of potential decision errors, and define the performance criteria limiting the decision errors.

This following describes decisions to be made based on the data and provides criteria on which these decisions will be made.

- Concisely describe the problem to be studied.

The problem being addressed is to ensure that representative and accurate real-time particulate and airborne CrVI data are collected to define the pre-construction particulate population reflective of routine background conditions.

- Identify what questions the study will attempt to resolve, and what actions (decisions) may result.

What are the pre-construction real time airborne Total PM and CrVI concentrations representative of routine city traffic conditions, including transportation, industrial, construction, and other sources of airborne Total PM and CrVI?

This data will be used to generate a Total PM Background Threshold Value (BTV) that in turn will be used as the site-specific

dust action level to ensure that the site perimeter and work zones are accurately monitored during construction to control any potential dust release in a timely manner.

- Identify the information that needs to be obtained and the measurements that need to be taken to resolve the decision statement.

Real-time total PM (direct reading instrumentation) and particulate CrVI data (laboratory analysis) using accurate, field and laboratory methods, including data quality review from multiple sampling locations (on site and off site) that are representative of urban conditions in the vicinity of the site.

- Define study boundaries and when and where data should be collected.

The study boundaries are the atmosphere at the site and adjacent urban area. Air monitoring stations will be located at the site perimeter and at off-site locations representative of urban conditions. The study will be conducted for a minimum of 15 consecutive calendar days and be completed prior to initiation of development construction activities.

3.3 *DATA QUALITY INDICATORS (DQIS)*

Data quality indicators (accuracy, precision, completeness, representativeness, comparability, and method detection limits) refer to quality control criteria established for various aspects of data gathering, sampling, or analysis activity. In defining DQIs specifically for the project, the level of uncertainty associated with each measurement is defined.

ERM has reviewed, understands and agrees with the DQI's defined by the contract laboratory Eastern Research Group, Inc.'s (ERG) Standard Operating Procedures (SOP), dated 14 February 2014, for hexavalent chromium analysis per ASTM D7614. Based upon our review and understandings of the DQIs provided in ERG's SOP, ERM has determined that the laboratory can meet the project needs.

- Accuracy is the degree of agreement of a measurement with a known or true value. To determine accuracy, a laboratory value is compared to a known or true concentration determined by such QC indicators as: matrix spikes, surrogate spikes, laboratory control samples (blind spikes) and performance samples. For the

Cr(VI) analyses covered under this SAP, accuracy will be determined according to the ASTM method – a filter method spike with acceptance criteria of 80% – 120%.

Accuracy shall be calculated as percent recovery of spiked analytes as follows:

$$\%R_i = (Y_i \div X_i) \times 100\%$$

where:

$\%R_i$ = percent recovery for compound i

Y_i = measured spike concentration in sample i
(sample concentration with the spike - original sample concentration)

X_i = actual spike amount in sample i

- Precision is the degree of mutual agreement between or among independent measurement of a similar site setting. Precision is expressed in terms of analytical variability. For this project, analytical variability will be measured as the relative percent difference (RPD) between results of duplicate monitors and between results of co-located samplers.

Precision will be calculated as the RPD as follows:

$$\%RPD_i = \frac{[O_i - D_i]}{(O_i + D_i)/2} \times 100\%$$

where:

$\%RPD_i$ = Relative percent difference for compound i

O_i = Value of compound i in original sample

D_i = Value of compound i in duplicate sample

Duplicate Total PM concentration data and co-located CrVI sample concentration results (“primary” and “duplicate”) will be compared to determine the RPD. The acceptable RPD for real-time Total PM is <40% and for CrVI is <20%.

- Completeness is expressed as percent of valid usable data actually obtained compared to the amount that was expected. According to EPA guidance, completeness goals in the range of 75% - 95% are typical. The target goal for completeness for this project is 100% percent for all data, given the critical importance of the data in establishing valid background concentrations. Completeness will be calculated as follows:

$$\%C = \frac{A}{I} \times 100\%$$

where:

$\%C$ = Percent completeness (analytical)

A = Number of usable sample results reported (all results not rejected)

I = Total number of results reported

Non-valid data (i.e., data qualified as “R” rejected) will be identified during the data review and the reasons for rejection explained in the data review report.

- Representativeness is the expression of the degree to which data accurately and precisely represent a characteristic of an environmental condition or a population. It relates both to the area of interest and to the method of taking the individual sample.

Representativeness of the environmental conditions at the time of sampling will be achieved by selecting sampling locations, methods, and times so that the data describe the urban air conditions that the project seeks to evaluate. Representative samples will also be ensured through following proper protocols for sample handling (storage, preservation, packaging, custody, and transportation), sample documentation, and laboratory sample handling and documentation procedures.

- Comparability expresses the confidence with which one data set can be compared to another. The comparability goal will be achieved by maintaining consistency in sampling conditions, selection of sampling procedures, sample preservation methods, and analytical methods as provided in ASTM D7614.

The method detection limit for CrVI as provided by the contract laboratory, ERG, is 0.0078 nanograms per milliliter (ng/mL) (0.0036 ng per cubic meter (M³) based on 21.6 M³ sample volume, i.e., 15 liters per minute for 24 hours).

Table 2 provides the summary of laboratory quality control procedures and corrective actions for evaluating laboratory QC samples.

Table 2. Summary of Quality Control Procedures for CrVI Analysis

Parameter	Frequency	Acceptance Criteria	Corrective Action
Initial 5-point calibration standards	Before every sequence	Correlation coefficient ≥ 0.995	1) Repeat analysis of calibration standards. 2) Prepare calibration standards and reanalyze.
Initial Calibration Verification (ICV)	Before every sequence, following the initial calibration	Recovery 85-115%	1) Repeat analysis of initial calibration verification standard. 2) Repeat analysis of calibration standards. 3) Prepare calibration standards and reanalyze.
Initial Calibration Blank (ICB)	One per Batch, following the ICV	Below MDL	1) Reanalyze. 2) Prepare blank and reanalyze. 3) Correct contamination and reanalyze blank. 4) Flag data of all samples in the batch.
Continuing Calibration Verification (CCV)	Every 10 samples and at the end of the analytical sequence	Recovery 85-115%	1) Repeat analysis of CCV. 2) Prepare CCV. 3) Flag data bracketed by unacceptable CCV.
Laboratory Control Sample	One per 10 samples	Recovery 80-120%	1) Reanalyze. 2) Prepare spike and reanalyze.
Replicate Analysis	Duplicate and/or Replicate samples only	RPD $< 20\%$ for concentrations greater than 5 x the MDL.	1) Check integration 2) Check instrument function 3) Flag samples

Parameter	Frequency	Acceptance Criteria	Corrective Action
Continuing Calibration Blank (CCB)	After every CCV and at the end of the sequence	Below MDL	1) Reanalyze. 2) Prepare blank and reanalyze. 3) Correct contamination and reanalyze blank. 4) Flag data of all samples in the batch.

3.4 DATA REVIEW AND VALIDATION

This section describes data review, including what organizations or individuals will be responsible for what aspects of data review and what the review will include. Since the data need to be legally defensible, data packages and data validation will be required. EPA defines validation as a 3rd party review of all laboratory data based on strict protocols. Data reviewed include raw data such as standards log books, extractions logs, instrument print outs, chromatograms (if applicable), mass spectra (if applicable), etc. Calibration data, sample analysis data, and quality control data are all evaluated.

3.4.1 Field Data Review

The process of reviewing field data will involve evaluating field records for consistency and completeness (i.e., ensuring that each sample result is fully supported by accurate metadata), reviewing QC and calibration information, evaluating whether the SOPs were followed **by conducting and documenting a field audit**, summarizing deviations and determining their impact on data quality, summarizing the samples collected, and providing a summary of the review in the project report.

Per ASTM Standard D7614-12, Section 13.6, the following conditions will render a sample invalid:

- 1) Filters that are dropped or become contaminated with any foreign matter (dirt, finger marks, ink); or
- 2) Filters with tears or pin holes; or
- 3) Start and stop flow rates differ by more than 10%; or
- 4) Filter samples collected by the samplers which operated less than 23 hours or more than 25 hours; or

- 5) A power failure occurs during a sample run which causes the stop time or sample duration requirements to be violated; or
- 6) Field blank fails if the concentration is higher than 3 times the method detection limit.

Field and laboratory analytical data will be summarized in tables as appropriate. ERM will perform a 100% check of all data presented on data summary tables, including review of all CrVI sampler total air volumes.

3.4.2

Laboratory Data Review and Validation

The laboratory will review the data internally in accordance with its SOP and established internal procedures prior to submitting the data to the ERM PM. Specifically, the laboratory will review the data package to ensure the following:

- Sample preparation information is correct and complete;
- Holding times have been met;
- Analytical information is complete and was generated within acceptable criteria;
- Any discrepancies/corrective actions identified during sample login, preparation or analysis have been addressed and documented;
- The appropriate SOPs have been followed;
- QC samples were within established control limits;
- Analytical requirements have been met (e.g., the correct analytical procedures were used as defined by the COC); and
- Documentation is complete and any QC issues are fully explained in a detailed case narrative.

Following receipt of the laboratory report, ERM will send the report (including raw data and all QA/QC information) to the designated third-party, independent validator. The third party will perform Level II validation, as described in EPA's *Guidance on Environmental Data Verification and Data Validation* (2002).

All data will be reviewed and verified by the ERM QA/QC Officer/PM or qualified designee (interchangeable herein throughout this document with "ERM PM"). The ERM PM will ensure that the field and technical data obtained for the project will provide the end user with acceptable data. All field and technical data shall be reviewed, by the ERM PM or a qualified designee, such as the ERM QA/QC Officer, to ensure that the data is accurate prior to the inclusion in the project report.

Data processing is summarized as follows:

1. The field data sheets (real-time Total PM and CrVI sampler), real-time instrument data logs, log books, and COC forms are submitted (faxed, electronic, or hard copy) by field personnel to the ERM PM weekly. The ERM PM, or their designee checks all forms for accuracy and ensures that each unique sample ID is correctly transposed across forms and logs accompanied by the correct metadata, then stores the information electronically into ERM's project files.
2. Samples are sent to the laboratory under COC.
3. The laboratory enters the sample information into their tracking system and performs the analysis.
4. The laboratory electronically submits raw data, sample results, and their QA information to ERM and to an independent third party validator, who in turn performs Level II validation, as described in EPA's *Guidance on Environmental Data Verification and Data Validation* (2002).
5. ERM submits the field data sheets, real-time instrument data logs, and COC forms to the third party validator.
6. The third party validator electronically submits their validation report to ERM.

Real-time Total PM concentration data will be provided as hourly averages based on one (1) minute frequency data collection. The daily average real-time Total PM concentration data will be used to calculate the dust action level, i.e., the background threshold value (BTV).

ERM reviews the data validation report, and, if acceptable, stores all data into the project files. If the result(s) of a CrVI analysis is found

unacceptable, ERM may request re-analysis of the data by the laboratory. Under this condition, the ERM PM will bring this result to the attention of EPA and MDE and request their concurrence of ERM's recommendation of whether or not to perform the re-analysis

3.6 *ASSESSMENT OVERSIGHT*

The QA program is described in the QAPP and is overseen by the QA/QC Manager for the project, Larry Hottenstein. All audit and assessment reports will be part of the project record and included in the final sampling report. The QA/QC Manager, or their designee will ensure that audits of data quality are being performed as follows:

- One field audit is planned for the 15-day sampling period. The audit will be conducted by the ERM QA/QC Manager and an audit report and corrective action(s), if any, will be submitted to the ERM PM. The field audit will include monitoring station siting, instrument maintenance and calibration and the initiation and recovery of a minimum of one CrVI sample.
- The laboratory's results of their latest laboratory audit and performance evaluation (PE) sample are appended to the QAPP to demonstrate laboratory compliance with QAQC requirements.
- The QA/QC Manager will review the field and lab quality assessments conducted as described in Sections 3.4.1 and 3.4.2, to ensure appropriate corrective actions are being taken, if warranted, and direct additional corrective measures if deemed necessary.

4.0

SAMPLING RATIONALE

Air quality data for establishing pre-construction concentrations for Total PM and particulate CrVI will be collected during a 15-day sampling period at three, fixed locations; one location will include a duplicate Total PM monitor and a duplicate CrVI sampler (60 CrVI samples collected in total). The pre-construction air monitoring station locations (Figure 2) were selected as representative of the site urban neighborhood background ambient air conditions as follows:

- Perimeter Air Monitor #1 (PAM-1) will be located approximately 400 feet east of Area 1, immediately adjacent to S. Caroline Street, representative of the urban residential neighborhood background air conditions;
- Off-Site Air Monitor #1 (OAM-1) will be located approximately 0.5 miles west of the site at the Baltimore National Aquarium, representative of Baltimore Inner Harbor waterfront background air conditions; and
- OAM - 2 will be located approximately 1.0 miles north of the site at the Old Town monitoring station established by MDE, representative of the urban background air conditions.

4.1

TOTAL PARTICULATE MATTER MONITORING

Real-time instrumentation is available to measure ambient concentrations of total particulate matter (Total PM). DustTrak Model 8533 real-time dust monitors have been selected for this study and are reported to monitor Total PM concentrations for particle sizes ranging from approximately 0.1 microns to 15 microns in diameter and is reported measure Total PM concentrations ranging from 1.0 $\mu\text{g}/\text{M}^3$ to 150 mg/M^3 .

4.2

HEXAVALENT CHROMIUM SAMPLING

Concurrently with real-time monitoring for Total PM using the DustTrak Model 8533, at each monitoring station location described above, airborne CrVI concentrations will be determined from 24-hour air samples collected using BGI Model PQ-100 samplers. CrVI air samples will be analyzed in accordance with the *Standard Operating Procedure for the Preparation and Analysis of Hexavalent Chromium by Ion Chromatography* as

prepared by ERG, dated 14 February 2014. A copy of the ERG SOP is provided in the QAPP, Appendix C.

5.0 *REQUEST FOR ANALYSES*

This section describe the analytical support for the project depending on several factors including the analyses requested, analytes of concern, turnaround times, available resources, available laboratories, etc.

5.1 *ANALYSES NARRATIVE*

Air samples will be collected at three (3) locations, one of which will include duplicate monitoring and co-located and sampling equipment. Expedited turn-around time of three (3) business days will be requested for the laboratory results for CrVI air samples to complete the study as soon as practicable after 15 days of sampling. Duplicate CrVI air samples will be collected at the PAM-1 co-located station location.

Air samples (including QC samples) will be analyzed for CrVI per ERG's SOP as provided in the project QAPP, Appendix C.

5.2 *ANALYTICAL LABORATORY*

ERG is an EPA contract laboratory and has provided their *Standard Operating Procedure for the Preparation and Analysis of Hexavalent Chromium by Ion Chromatography*, dated 14 February 2014, and provided in the QAPP, Appendix C

6.0 *FIELD METHODS AND PROCEDURES*

Descriptions of the equipment, methods and procedures that will be used to accomplish the air sampling goals are provided in this section. It should be noted that personnel involved in sampling must wear clean, disposable, powder-free, nitrile gloves. Descriptions of sample tracking and shipping are provided in Section 7.

6.1.1 *List of Equipment Needed*

The equipment and materials that will be used in the field to collect samples are listed below:

- DustTrak Model 8533 monitors will be operated in the field to collect real-time Total PM concentration data. . One (1) back-up DustTrak Model 8533 monitor will be available throughout the study;
- BGI PQ-100 samplers will be used to collect air samples for CrVI laboratory analysis. One (1) back-up DustTrak Model 8533 and one (1) back-up BGI PQ-100 sampler will be available throughout the study;
- Bios Defender 510-H primary flow calibrator;
- Laboratory prepared filters mounted in holders;
- Teflon tubing and connectors;
- Shipping coolers and packing/sealing supplies;
- Electric extension cords and ground fault interrupter/surge protectors;
- Weather proof equipment cases and tripods;
- Disposable, powder-free, nitrile gloves and Teflon tweezers;
- Maintenance tool kit; and
- First Aid kit.

6.1.2 *Calibration of Field Equipment*

The DustTrak Model 8533 monitors will be calibrated daily at the beginning and end of each 24-hour sampling period utilizing a BIO Defender 510-H primary air flow calibration meter. The BGI-PQ100 samplers monitors will be calibrated daily at the beginning and end of each 24-hour sampling period utilizing a BGI TetraCal primary air flow calibration meter. The DustTrak Model 8533 monitor beginning flow rate will be calibrated to two (2) Lpm and the BGI-PQ100 sampler will be calibrated to 15 Lpm, with the air sampling media attached to the sampler.

Equipment maintenance and calibration records for the project will be maintained at the site office and in project files stored on ERM's server.

Details of calibration methods are included in the SOPs for each instrument being utilized for the project in the QAPP, Appendix B. All calibration information will be recorded daily on the field data sheets also provided in the project QAPP, Appendix B. Field data sheets will be transmitted daily to the ERM office, checked as described above, and stored on ERM's secure server.

6.2 *AIR*

6.2.1 *Total Particulate Matter*

Fixed, Total PM air monitoring locations will be established in the field as shown on Figure 2. DustTrak Model 8533 real-time dust will be operated continuously 24 hours per day, seven (7) days per week at the three (3) monitoring station locations during the 15 consecutive days of pre-construction air monitoring program for measurement of Total PM concentrations. DustTrak Model 8533 monitors will be operated at two (2) Lpm and will be calibrated daily at the time of the CrVI sample recovery.

Air sampling inlets will be set at a height of no less than two (2) meters above ground surface. The siting requirements described in 40 CFR Part 58, Appendix E will be used as guidance. The duplicate DustTrak Model 8533 monitors at PAM-1 will be connected to a "T" to ensure the same air stream is being monitored by both instruments.

Specific monitoring station siting information including exact locations, labeled aerial and ground level photographs, and electric power and security provisions is provided in Appendix A.

6.2.2

Hexavalent Chromium Sampling

Fixed CrVI air sampling locations will be established in the field as shown on Figure 2. BGI-PQ100 air samplers will be operated continuously 24 hours per day, seven (7) days per week at the three (3) monitoring station locations during the 15 consecutive days of pre-construction air monitoring program for laboratory analysis of CrVI concentrations. BGI-PQ100 air samplers will be operated at 15 Lpm and will be calibrated daily at the time of the CrVI sample recovery.

Air sampling inlets will be set at a height of no less than two (2) meters above ground surface. The siting requirements described in 40 CFR Part 58, Appendix E will be used as guidance. The co-located BGI-PQ100 air samplers at PAM-1 will be sited two (2) to four (4) meters apart.

Air samples will be collected using laboratory provided nitric acid and sodium bicarbonate pre-treated filters mounted into filter holders. Laboratory prepared filters/holders will be shipped from the laboratory, maintained in the field, and returned to the laboratory frozen at 0°C.

The following procedure will be used for installation and recovery of the filter holder containing the sample filter and sample inlet apparatus.

- 1) Ensure that the sample media are delivered to the sample site within a cooler with ice packs to keep the filters cold and protected from the elements.
- 2) Prior to installation of the filter holder and glass funnel apparatus onto the PQ100 sampler, ensure that the sampler is free of dust and debris buildup. Wipe the sampler down with a damp cloth as appropriate.
- 3) Wearing powder-free nitrile gloves, remove the filter holder from its packaging. Note the filter ID (if so identified by the lab). If the filter is not marked with an identifying number, mark the filter holder packaging with an appropriate sample ID indicating sample location, day, and time. Record all sample media identification on the field data sheet. The field data sheet is included as an attachment to this SOP and is also used as the COC (Chain-of-Custody).
- 4) Mark the corresponding glass funnel inlet assembly packaging with the same identification parameters as the filter holder.
- 5) Loosen the nut on the filter holder outlet fitting and remove the Teflon plug. Store the Teflon plug in the filter holder packaging to protect it from contamination. Install the filter holder onto the end of the stainless steel U-tube by inserting the tubing into the filter holder outlet fitting and tightening the nut.
- 6) Leave the Teflon plug in the inlet side of the filter holder until ready to perform the initial flow rate verification.
- 7) After ensuring all sample run data has been collected from the PQ100 unit, including the total sample volume, replace the Teflon plug in the filter holder inlet and tighten the nut.

- 8) Remove the filter holder from the sampler by loosening the nut on the outlet fitting and removing from the stainless steel U-tube.
- 9) Replace the Teflon plug at the filter holder outlet and tighten the nut.
- 10) Place the sample holder into a labeled, zip-lock plastic bag and place in the cooler with ice packs as soon as possible to maintain sample integrity during storage and shipping.

In the process of collecting environmental samples during the air monitoring study, the ERM sampling team will generate different types of potentially contaminated IDW that include the following:

- Used personal protective equipment (PPE) in the form of used nitrile gloves.
- Disposable sampling equipment in the form of Teflon tweezers.

The EPA's National Contingency Plan (NCP) requires that management of IDW generated during sampling comply with all applicable or relevant and appropriate requirements (ARARs) to the extent practicable. The sampling plan will follow the Office of Emergency and Remedial Response (OERR) Directive 9345.3-02 (May 1991), which provides the guidance for the management of IDW. In addition, other legal and practical considerations that may affect the handling of IDW will be considered.

- Used PPE and disposable equipment will be double bagged and placed in a municipal refuse dumpster. These wastes are not considered hazardous and can be sent to a municipal landfill.

9.0 *SAMPLE DOCUMENTATION AND SHIPMENT*

9.1 *FIELD NOTES*

Field records (sample collection sheets and field logs of daily activities) will be maintained in the field office and on ERM's server and will include logbooks, preprinted sampling data forms, photographs, sample shipment tracking logs and copies of sample Chain of Custody.

9.1.1 *Field Logbooks*

Field logs will be used to document daily field activities and will be prepared and maintained by the Field Technician responsible for air monitoring. Preprinted sampling data forms will also be utilized to document specific sampling information. At a minimum, the following information will be recorded during the collection of each sample:

- Sample location and description
- Sampler's name(s)
- Date and time of sample collection
- Designation of sample as composite or grab
- Type of sample (air)
- Type of sampling equipment used
- Field instrument readings and calibration
- Field observations and details related to analysis or integrity of samples (e.g., weather conditions, damaged filter media, etc.)
- Sample preservation
- Lot numbers of the sample containers, sample identification numbers and any explanatory codes, and chain-of-custody form numbers
- Shipping arrangements (overnight air bill number)
- Name(s) of recipient laboratory(ies)

In addition to the sampling information, the following specific information will also be recorded in the field logbook for each day of sampling:

- Team members and their responsibilities
- Time of arrival/entry on site and time of site departure
- Other personnel on site
- Summary of any meetings or discussions with tribal, contractor, or federal agency personnel
- Deviations from sampling plans, site safety plans, and QAPP procedures
- Changes in personnel and responsibilities with reasons for the changes
- Levels of safety protection
- Calibration readings for any equipment used and equipment model and serial number

9.1.2 *Photographs*

Photographs will be taken at the sampling locations. They will serve to verify information entered in the field logbook. For each photograph taken, the following information will be written in the logbook or recorded in a separate field photography log:

- Time, date, location, and weather conditions
- Description of the subject photographed
- Name of person taking the photograph

9.2 *LABELING*

All samples collected will be labeled in a clear and precise way for proper identification in the field and for tracking in the laboratory. The samples will have preassigned, identifiable, and unique numbers. At a minimum, the sample labels will contain the following information: station location,

date of collection, analytical parameter(s), and method of preservation. Every sample will be assigned a unique sample number.

9.3 *SAMPLE CHAIN-OF-CUSTODY FORMS AND CUSTODY SEALS*

All sample shipments for analyses will be accompanied by a chain-of-custody (COC) record. COC's will be completed and sent with the samples to the laboratory and each shipment (i.e., each day).

The chain-of-custody form will identify the contents of each shipment and maintain the custodial integrity of the samples. Generally, a sample is considered to be in someone's custody if it is either in someone's physical possession, in someone's view, locked up, or kept in a secured area that is restricted to authorized personnel.

Samples will be maintained prior to and following sampling in a dedicated, secured freezer inside the Honeywell Transfer Station at the project site. Until the samples are shipped, the custody of the samples will be the responsibility of ERM. The sampling Field Technician will sign the chain-of-custody form in the "relinquished by" box and note date, time, and air bill number.

The sample numbers for all filter media blanks, field handling blanks and duplicates will be documented on this form (see Section 10.0). A photocopy will be made for the EPA's and MDE's project files.

A self-adhesive custody seal will be placed across the top of each sample filter holder. The shipping containers in which samples are stored will be sealed with self-adhesive custody seals any time they are not in someone's possession or view before shipping. All custody seals will be signed and dated.

9.4 *PACKAGING AND SHIPMENT*

All sample containers will be placed in a strong-outside shipping container. The following outlines the packaging procedures that will be followed for low concentration samples.

1. Ice packs will be used to eliminate melting ice from damaging the sample holders..
2. The bottom of the cooler should be lined with bubble wrap to prevent breakage during shipment.

3. Check filter holder inlet and outlet caps for tightness.
4. Secure container tops with clear tape and custody seal all container tops.
5. Affix sample labels onto the containers with clear tape.
6. Seal all sample containers in heavy duty plastic zip-lock bags. Write the sample numbers on the outside of the plastic bags with indelible ink.
7. Place samples in a sturdy cooler lined with Styrofoam and plastic. Enclose the appropriate COC(s) in a zip-lock plastic bag affixed to the underside of the cooler lid.
8. Fill empty space in the cooler with bubble wrap or Styrofoam peanuts to prevent movement and breakage during shipment.
9. Ice packs will be used to maintain the 0°C temperature requirement during shipping.
10. Each cooler will be securely taped shut with fiberglass strapping tape, and custody seals will be affixed to the front, right and back of each cooler.

Records will be maintained by ERM's PM of the following information:

- Sampling contractor's name (if not the organization itself).
- Name and location of the site.
- Total number of samples shipped to the laboratory.
- Carrier, air bill number(s), method of shipment (priority next day).
- Shipment date and when it should be received by lab.
- Irregularities or anticipated problems associated with the samples.
- Whether additional samples will be shipped or if this is the last shipment.

10.0 *QUALITY CONTROL*

This section describes the quality control samples that are being collected to support the sampling activity, including field and trip blank samples. All quality control samples will be sent to the laboratory blind.

10.1 *FIELD QUALITY CONTROL SAMPLES*

Field quality control samples are intended to help evaluate conditions resulting from field activities and are intended to accomplish two primary goals: assessment of field contamination; and assessment of sampling variability. The former assesses for substances introduced in the field due to environmental or sampling equipment and is assessed using blanks of different types. The latter assesses variability due to sampling technique and instrument performance as well as variability possibly caused by the heterogeneity of the matrix being sampled and are assessed using replicate sample collection. The following sections cover field QC samples.

10.1.1 *Assessment of Field Contamination (Blanks)*

Field contamination is usually assessed through the collection of different types of blanks. Field blanks are sample containers handled in the field. Trip blanks are prepared by the laboratory and shipped to and from the field.

10.1.1.1 *Field Blanks*

Field blanks are collected during air sampling. One (1) field blank is prepared each day sampling occurs in the field. These blanks are submitted "blind" to the laboratory, packaged like other samples and each with its own unique identification number.

The field blanks will be preserved, packaged, and sealed in the manner described for the CrVI air samples. A separate sample number and station number will be assigned to each sample, and it will be submitted blind to the laboratory.

10.1.1.2 *Trip Blanks*

Trip blanks will be prepared to evaluate if the shipping and handling procedures are introducing contaminants into the samples. A minimum of one trip blank will be submitted to the laboratory for analysis with every shipment of samples for CrVI analysis. Trip blanks are filter media that

have been shipped to the site prior to sampling. The sealed trip blanks are not opened in the field and are shipped to the laboratory in the same cooler with the samples collected for CrVI analyses. The trip blanks will be preserved, packaged, and sealed in the manner described for the CrVI samples. A separate sample number and station number will be assigned to each trip sample and it will be submitted blind to the laboratory.

10.1.2 *Assessment of Field Variability*

Duplicate samples are collected simultaneously with a standard sample from the same source under identical conditions into separate sample containers. Field duplicates will be collected using a co-located sampler. Each duplicate portion should be assigned its own sample number so that it will be blind to the laboratory. A duplicate sample is treated independently of its counterpart in order to assess laboratory performance through comparison of the results. At least 10% of samples collected per event will be field duplicates.

Duplicate real-time Total PM concentration data and CrVI samples will be collected daily at sample location PAM-1.

Duplicate samples will be collected from this monitoring station because the location is closest to the project site and is representative of urban neighborhood ambient air conditions.

Duplicate samples will be preserved, packaged, and sealed in the same manner as other samples of the same matrix. A separate sample number and station number will be assigned to each duplicate, and it will be submitted blind to the laboratory.

10.2 **LABORATORY QUALITY CONTROL SAMPLES**

Laboratory quality control (QC) samples are analyzed as part of standard laboratory practice. The laboratory monitors the precision and accuracy of the results of its analytical procedures through analysis of QC samples. In part, laboratory QC samples consist of matrix spike and duplicate samples for CrVI analyses. The term "matrix" refers to use of the actual media collected in the field.

11.0

FIELD VARIANCES

As conditions in the field may vary, it may become necessary to implement minor modifications to sampling as presented in this plan. When appropriate, the QA Officer, EPA and MDE representatives will be notified and a verbal approval will be obtained before implementing the changes. Modifications to the approved plan will be documented in the sampling project report.

Project-specific health and safety procedures that must be followed in the field include the use of clean, disposable, powder-free, nitrile gloves whenever handling the sampling tubing, connectors or sample filter media. Potential hazards that may be encountered are electric shock caused by contact with operating electronic monitoring or sampling equipment during wet sampling periods. Caution must be taken at all times to maintain dryness inside the water proof cases protecting the electronic equipment, thereby protecting field personnel from possible electric shock.

Figures

Figure 1
Site Location Map

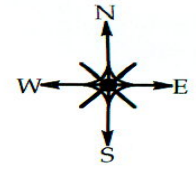
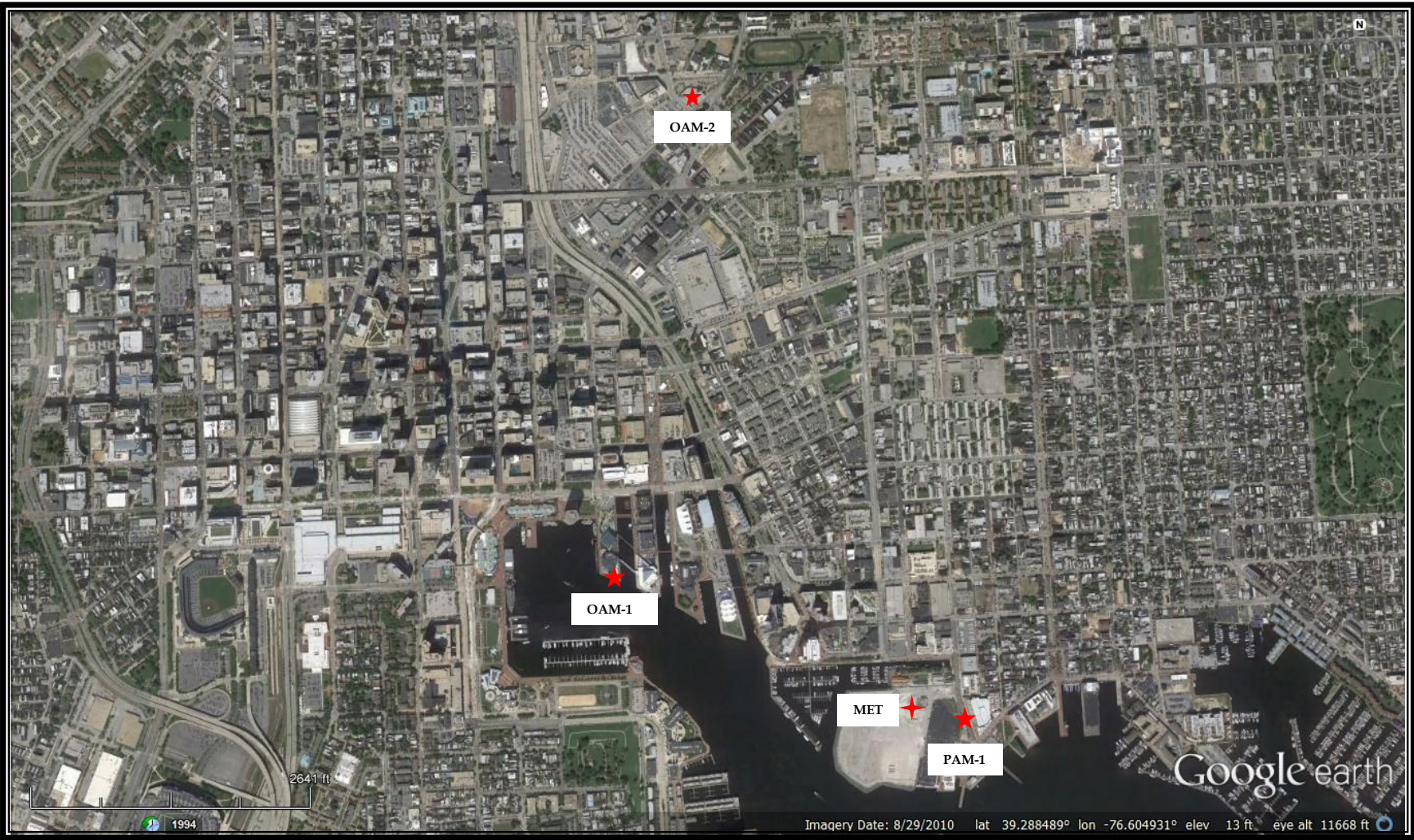
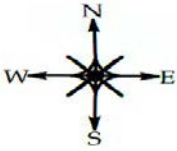

Figure 2
Pre-construction Air Monitoring Locations
Harbor Point
Baltimore, Maryland



MET - Meteorological Station
PAM - Perimeter Air Monitor
OAM - Off-site Air Monitor
1 - Baltimore National Aquarium
2 - MDE's Old Town Station

APPENDIX A
SITING INFORMATION

Baltimore City/Inner Harbor Vicinity – Air Monitoring Station Locations

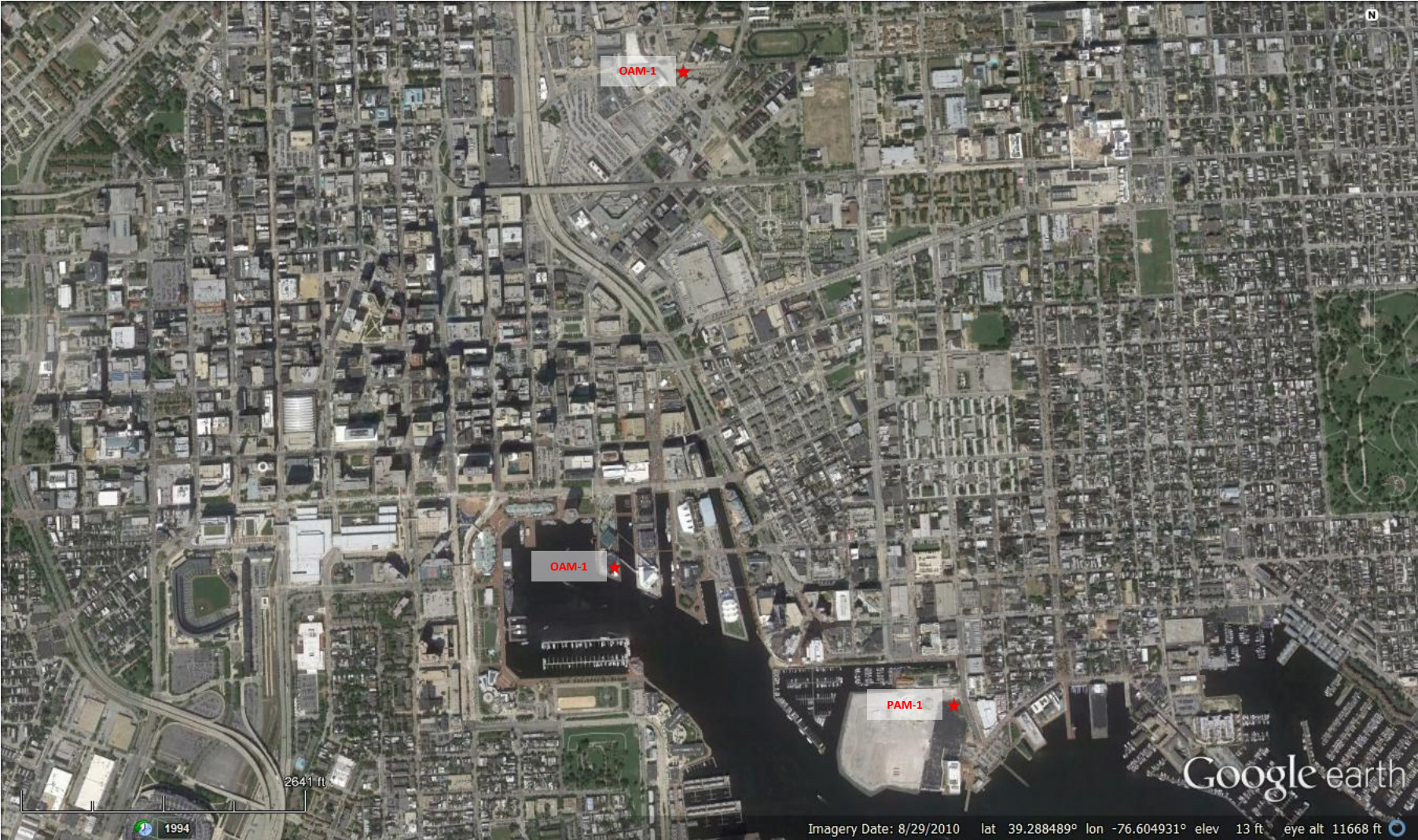

Perimeter Air Monitor (PAM-1)
900 Block S. Caroline Street
Baltimore, MD 21231

Lat./ Long. provided

Electric power from and secure to
parking lot light pole

(Same location as AM-3 during Apr. –
Jun. 2013 study.)

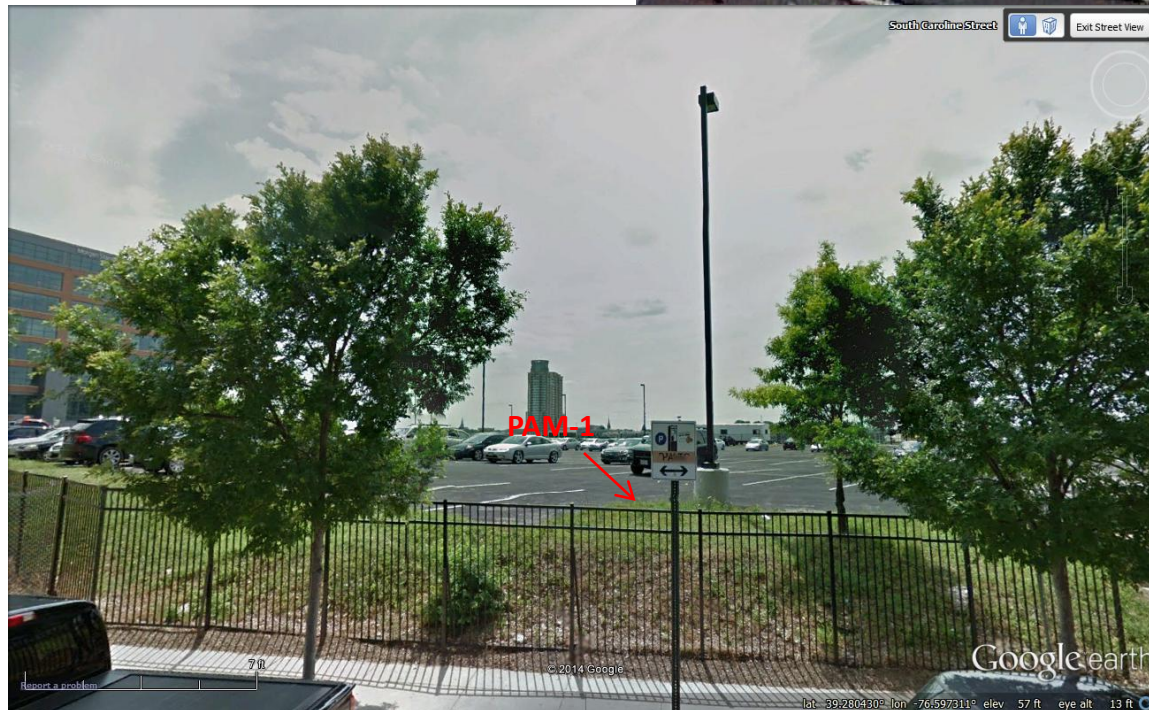
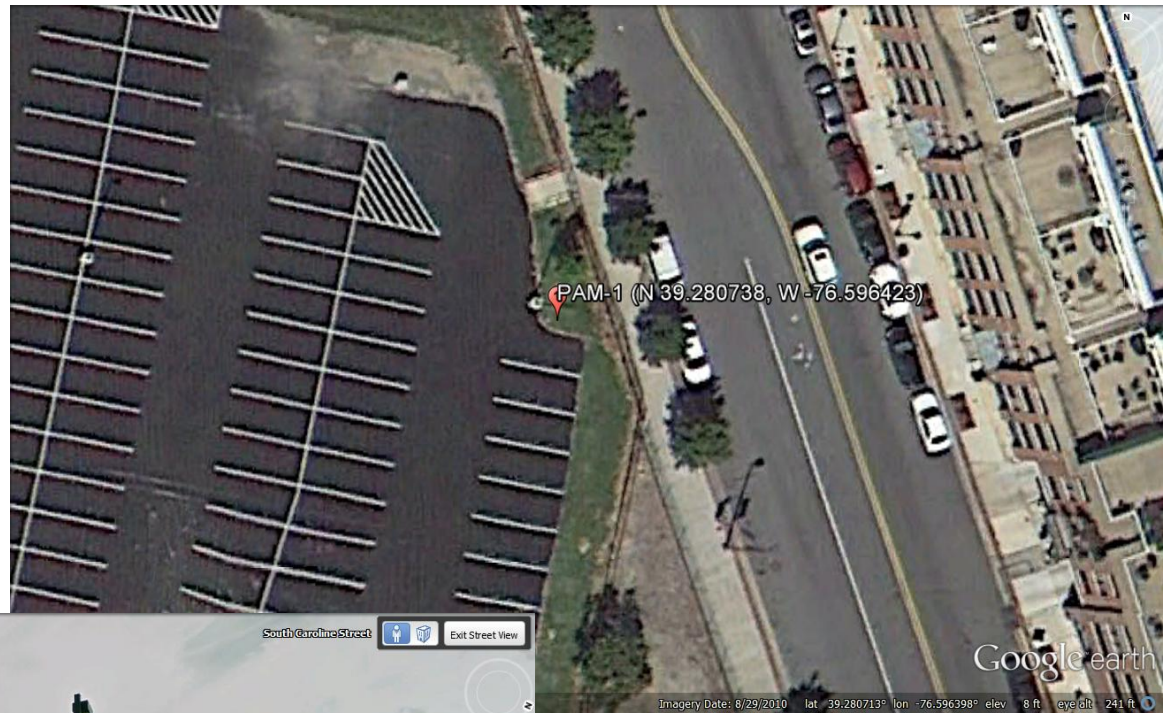

Off-Site Air Monitor (OAM-1)
Baltimore National Aquarium
501 E. Pratt Street
Baltimore, MD 21202

Lat./ Long. provided

Electric power from light pole. Site
behind and secure to concrete bench.

(Same location as OAM-2 during Jun. –
Jul. 2013 study.)

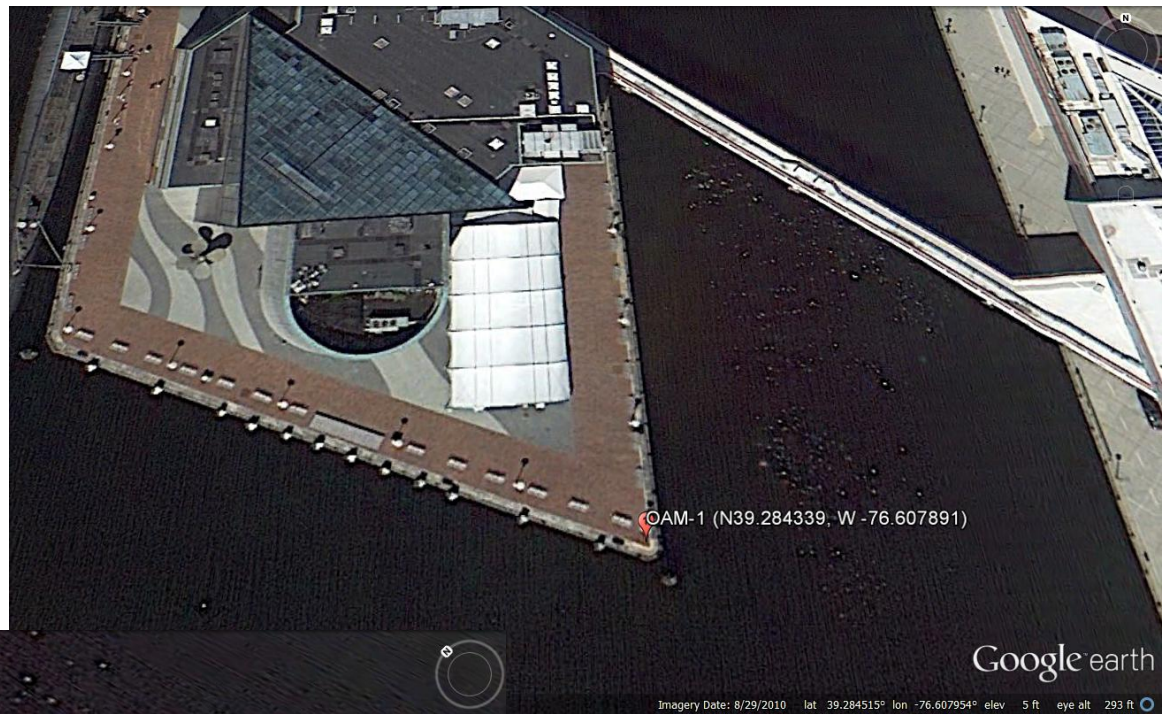

Off-Site Air Monitor (OAM-2)
Thomas J. Burke Fire Station
1100 Hillen Street
Baltimore, MD 21202

Lat./ Long. provided

Electric power from MDE shelter. Site inside fenced area and secure to chain link fence.

(MDE Monitoring Location)

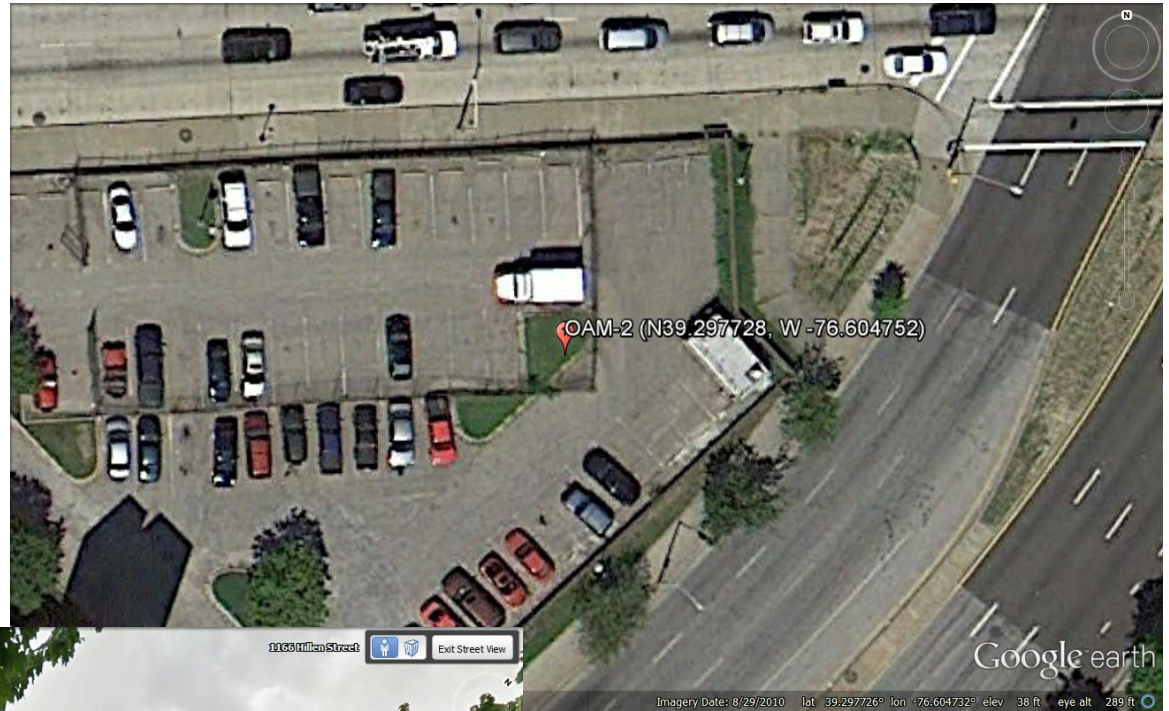

Appendix B
Field Sampling Method SOPs



Field Sampling Protocol and Standard Operating Procedure

**REAL-TIME AIR SAMPLING FOR TOTAL PARTICULATE MATTER
IN AMBIENT AIR**

February 2014

**REAL-TIME AIR SAMPLING FOR TOTAL
PARTICULATE MATTER IN AMBIENT AIR**

February 2014

By:

Environmental Resources Management Inc.
Harbor Point Development LLC

For:

U.S. Environmental Protection Agency - Region III
Maryland Department of the Environment

TABLE OF CONTENTS

APPENDICES..... I

1.0 INTRODUCTION..... 1

2.0 EQUIPMENT LIST 1

3.0 HEALTH AND SAFETY 2

4.0 MONITOR SET-UP AND OPERATION..... 2

4.1 DRX AEROSOL MONITOR MODEL 8533..... 2

4.2 INSTALLATION 3

5.0 INITIAL MONITOR SETUP AND PROGRAMMING 3

5.1 INSTRUMENT SETUP..... 3

5.2 SETUP MENU 4

5.3 ZERO CALIBRATION..... 5

5.4 SAMPLE FLOW RATE SETTING 6

5.5 MONITOR DATE AND SETTINGS..... 7

6.0 MONITOR OPERATION 8

7.0 TAKING MASS CONCENTRATION MEASUREMENTS..... 9

8.0 ALARM..... 11

9.0 MONITOR MAINTENANCE..... 14

10.0 CONTACTS..... 18

APPENDICES

A FIELD DATA SHEET

1.0 INTRODUCTION

This protocol and standard operating procedure (SOP) is intended to provide a general overview and step-by-step instructions for personnel in the field responsible for carrying out real-time ambient air sampling for total particulate matter (Total PM). The instructions cover assembly of the instrument, instrument programming and operation, deployment and field data recording. This SOP has been prepared in accordance with the guidance documents *Guidance for Preparing SOPs* (USEPA 2007) and *Quality Assurance Handbook for Air Pollution Measurement Systems* (USEPA 1994, USEPA 2008).

This document assumes that instrument location siting has already been successfully completed ensuring each location meets the acceptable criteria with regards to the proximity of obstructions (i.e. buildings, trees, etc.), technician safety, and any potential contamination contributions from surrounding operations.

2.0 EQUIPMENT LIST

The following equipment will be required for the air monitoring program:

- DustTrak® DRX Aerosol Monitor Model 8533, including:
 - TrakPro™ Software
 - Zero Filter
 - Power Supply
 - 6600 mAH Lithium Ion Rechargeable Battery
 - USB Cable
 - Analog alarm/output cables
 - Calibration Certificate
 - Spare Internal Filter Elements
 - Flexible Teflon tubing and connectors
- BIOS Defender 510-H Air Flow Calibrator unit;
- Laptop PC with TrakPro™ Software;
- Waterproof case for each instrument;
- Rigid stand with legs to support Waterproof case 2 meters above ground; and
- Field data sheets – provided in Appendix A, clipboards, pens.

Additional Field Supplies:

- Miscellaneous tools (wrenches, screwdrivers, pliers, etc.);
- Electric extension cords;
- Ground Fault Interrupter power strips

- Personal protective equipment (PPE), see the site specific Health and Safety Plan (HASP);
- Field notebook.

3.0 HEALTH AND SAFETY

All monitoring activities undertaken at the Site must be completed under the approved, site-specific HASP. The HASP identifies the hazards, personal protective equipment, monitoring, and emergency procedures for conducting work at the Site. Monitoring and support personnel must acknowledge their review of the HASP prior to performing work at the Site.

4.0 MONITOR SET-UP AND OPERATION

4.1 DRX AEROSOL MONITOR MODEL 8533

The monitor used within this SOP is the DustTrak® DRX Aerosol Monitor Model 8533 (the “monitor”) manufactured by TSI Incorporated. The monitor employed during this program uses TrakPro™ Software. The DRX 8533 monitors Total PM concentration and stores 1-minute averages on an internal data logger. The instrument measures real-time aerosol mass readings using light-scattering laser photometers for particles approximately 15 µm or less in diameter. The DRX 8533 monitors can be operated at flow rates up to three (3) liters per minute (Lpm). Figure 1 presents the typical DRX 8533 monitor.



Figure 1. DRX8533

For purposes of this monitoring program, the DRX 8533 monitor will be operated in the “Total” mass concentration channel, i.e., Total PM data collection without the particle size impactor.

The DRX 8533 contains an internal 6600 mAH Lithium Ion rechargeable battery. For purposes of this monitoring program, AC power will be available for providing the

monitor with constant power therefore the internal battery will only be used to maintain instrument operation in the event monitoring could be interrupted by AC power loss.

4.2 *INSTALLATION*

This document assumes that sample locations have already been sited and adhere to the proper sample location criteria. The monitor should be placed on a reasonably level surface with the sample inlet at a height of no less than two (2) meters with unobstructed air flow for at least 270 degrees around the monitor. For duplicate monitoring, each monitor will be connected to the same monitor inlet.

The monitors should be secured from the effects of wind loading to prevent tipping over in elevated wind conditions. The tripod stand with weatherproof case housing the monitor can be secured with cinder blocks on each leg and will be attached by chain with lock to an unmovable object to protect from theft.

5.0 *INITIAL MONITOR SETUP AND PROGRAMMING*

5.1 *INSTRUMENT SETUP*

The DustTrak DRX monitor can be connected to a computer to download data and upload sampling programs.

Connecting to the Computer

Connect the USB host port of a Microsoft[®] Windows[®]-based computer to the USB device port on the side of the DustTrak monitor.

Installing TrakPro[™] Data Analysis Software

TrakPro software can preprogram the DustTrak monitor, download data, view and create raw data and statistical reports, create graphs, and combine graphs with data from other TSI instruments that use TrakPro software. The following sections describe how to install the software and set up the computer.

Note

To use TrakPro software with the DustTrak Aerosol Monitor, the PC must be running Microsoft Windows® and the computer must have an available Universal Serial Bus (USB) port.

®Microsoft and Windows are registered trademarks of Microsoft Corporation

1. Insert the TrakPro Data Analysis Software CD into the CD-ROM drive.
The install screen starts automatically.

Note

If the software does not start automatically after a few minutes, manually run the program listed on the label of the CD using the **Run** command on the Windows Start Menu.

2. Follow the directions to install TrakPro software.

TrakPro software contains a comprehensive installation guide. TSI recommends printing out this guide prior to starting the TrakPro software installation on your computer, so it may be consulted during the installation. The TrakPro Software manual is located in the Help file in TrakPro software. There is no separately printed TrakPro Data Analysis software manual.

5.2 SETUP MENU

Pressing Setup activates the Setup Menu touchscreen buttons along the left edge of the screen. Setup is not accessible when the instrument is sampling.

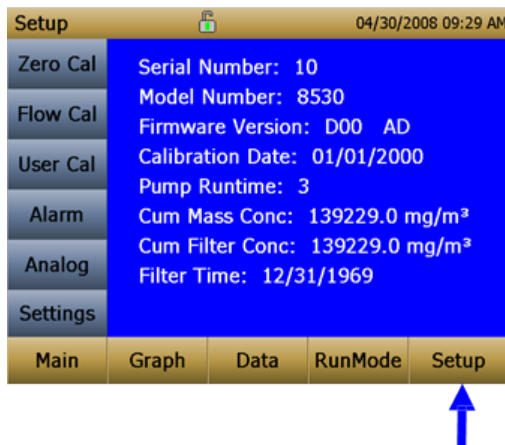

The main screen of the **Setup** screen displays the following information:

Serial Number	The instruments serial number.
Model Number	The instruments model number.
Firmware	Instruments current version of firmware.
Calibration Date	Date of the last factory calibration.
Pump Run Time	Pump running time in hours.
Cum Mass Conc.	Amount of mass run through instrument over life.
Cum Filter Conc.	Amount of mass run through instrument since last filter
Filter Time	Date of last filter change.

5.3 *ZERO CALIBRATION*

TSI recommends performing a zero check prior to each use for the DustTrak monitor, before running any extended tests, and after the instrument experiences a significant environmental change. Examples of significant environmental changes would be ambient temperature changes that exceed 15°F (8°C) or moving from locations with high aerosol concentrations to low concentrations.

Zeroing Instrument



Run **Zero Cal** prior to every 24-hour sampling event. Zero Cal requires that the zero filter be attached prior to running. Zero Cal must also be performed if the unit is reading negative concentrations. It is not possible for the DustTrak monitor to read negative concentrations. Negative concentrations are a symptom of zero drift.

Zero Cal

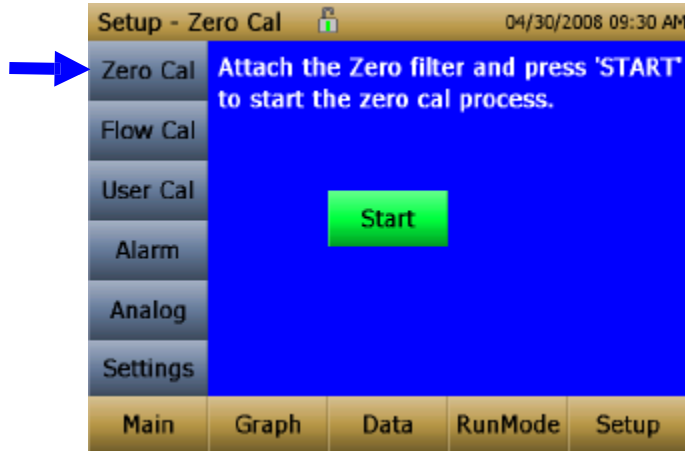

Never perform a zero cal. without attaching a zero filter.

1. Press Zero Cal Button
2. Attach Zero Filter
3. Press the **Start** button to start Zeroing process.
4. A count-down clock will appear indicating the time remaining. The screen with indicate Zero Cal Complete when done.

Remove filter after zeroing has been completed. The instrument is now zero calibrated and ready for use.

5.4 SAMPLE FLOW RATE SETTING

For purposes of this monitoring program, the flow rate setting shall be 2.0 Lpm. For DustTrak DRX Model 8533, *the flow cannot be changed*. Run **Flow Cal** to calibrate the flow set point. The flow set point is factory set to 3 Lpm total flow; two (2) Lpm of the total flow is measured aerosol flow, and one (1) Lpm of total flow is split off, filtered, and used for sheath flow. There is an internal flow meter in the DustTrak DRX instrument that controls flow rate to $\pm 5\%$ if factory set point. TSI recommends checking the flows with an external flow reference meter, especially when collecting data. The pump will automatically start when entering the Flow Cal screen.

Flow Cal

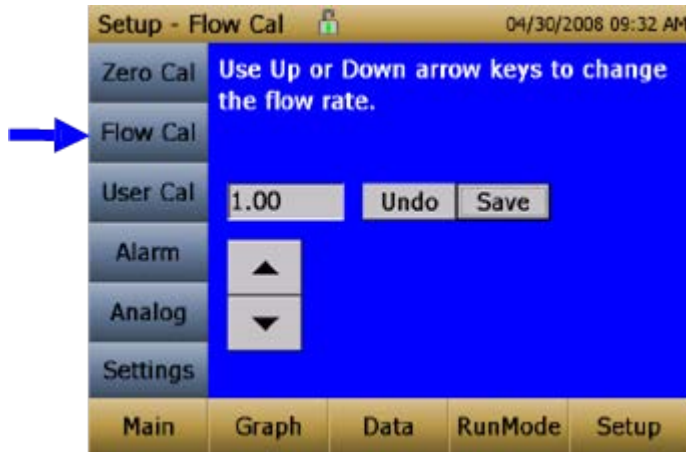

1. Attach a flow calibrator (BIOS Defender 510-H) to inlet port.
2. Move the arrows up or down to achieve desired flow on the reference flow meter. Each up or down arrow will change the flow about 1%. Allow time between button presses to let pump change to the new flow rate.
3. Select **Save** once the desired flow rate is achieved. Select **Undo** to return to the factory set point.
4. Record the calibration data in the field logbook.

5.5 MONITOR DATE AND SETTINGS

Set the DRX 8533 to the correct date and time prior to use. Follow the procedure below for setting the monitor date and time.

Settings

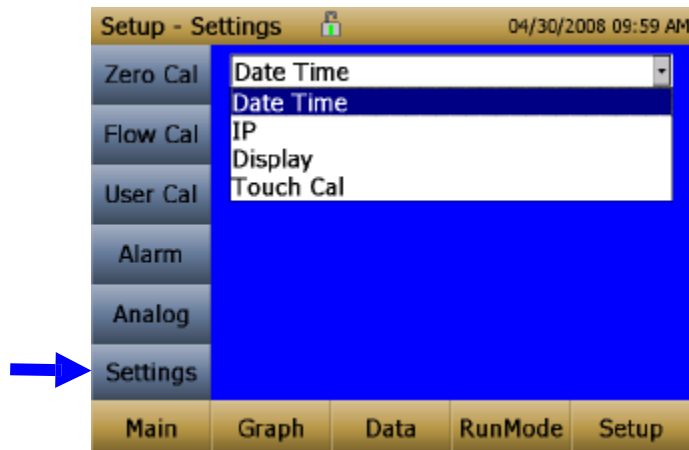

Settings screen sets basic unit parameters:

Set current date, current time and date/time format. Time can be set in 12 or 24 hour format. Date can be set in yyyy/dd/mm, yyyy/mm/dd or mm/dd/yyyy. The date format for the project will be **yyyy/mm/dd** to ensure consistency with the format adopted all other sampling documentation.

6.0 MONITOR OPERATION

Follow the procedure below for operating the DRX 8533 aerosol monitor:

The **RunMode** tab brings up sampling mode options.

Run Mode

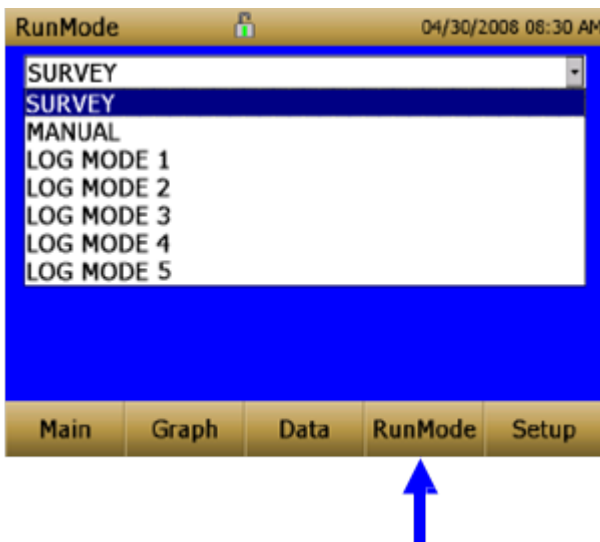

Sampling mode options include **Survey Mode**, **Manual Log**, and **Log Mode 1-5**.

Survey	Survey Mode runs a real time, continuous active sample, but does not log data.
Manual	Manual Log sets the instrument to log data for a specified run time
Log Modes	Log Mode starts and stops the instrument at specified times, run for a specified test length, and perform multiple tests of the same length with a specified time period between tests.

The **Manual** sampling mode is to be set for this project.

Manual Mode

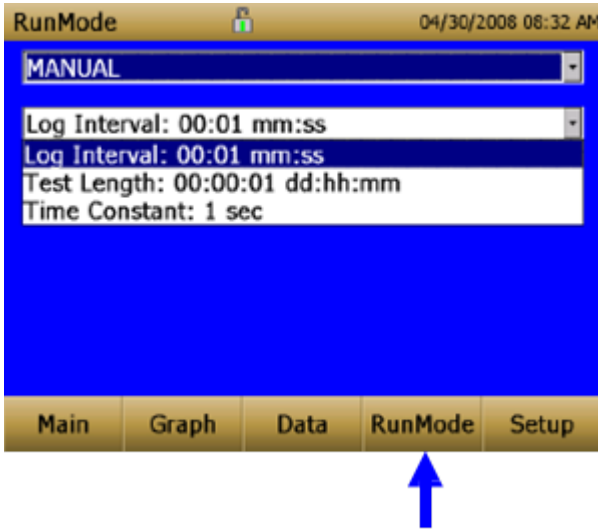

Log Interval	The log interval can be set from 1 second to 60 minutes. It is the amount of time between logged data points.
Test Length	Test length can be set from 1 minute to the limit of the data storage.
Time Constant	Time Constant can be set from 1 to 60 seconds. This will control the update rate of the main screen. It is the rolling average of data displayed on the main screen and is not linked to logged data in either Manual or Program Log modes.

The Log Interval will be set to one (1) minute, the Test Length will be set to allow 24-hours storage (“storage limit”) and the Time Constant will be set to one (1) second for this project. In Manual mode, data will be stored to a file named –*Manual_XYZ* where XYZ is an incrementing integer.

7.0 TAKING MASS CONCENTRATION MEASUREMENTS

Measurements are started and controlled from the main screen. The Total mass concentration will be selected for measurement and display. Prior to starting a measurement the instrument should be zeroed from the Setup screen and the run mode should be configured and selected from the RunMode screen.

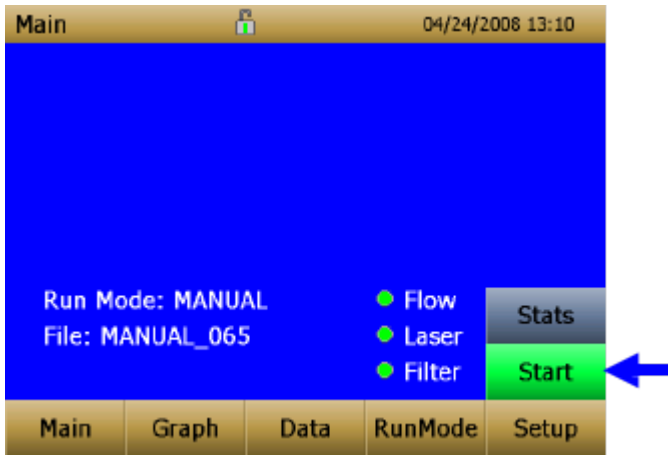

When the instrument is on, but not taking any mass measurements the start button will be green and instruments pump will not be running. To start taking a measurement, press the green **Start** button.

While taking a measurement the screen will display the current measured mass concentration. The various regions of the screen are shown below:

Screen Regions

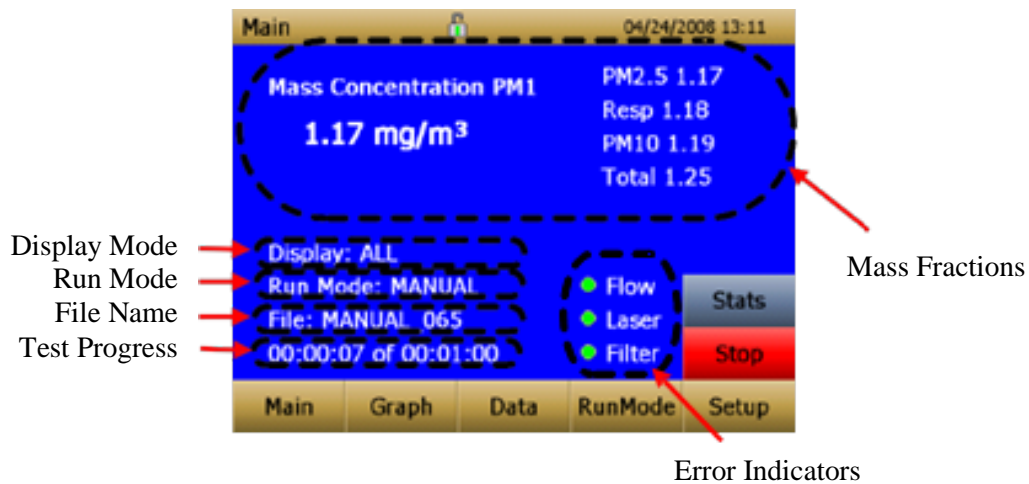

<p>Mass Fractions Region (live keys)</p>	<p>Shows the size segregated mass measurements. The highlighted channel displayed in larger font on the left can be changed by touching on the screen the measurement of most interest on the right- hand side of the screen. Set the Total channel as the highlighted display during monitoring.</p>
---	---

Display Mode Region (live key)	The size segregated mass fractions displayed in this area can be selected by touching in the -Display mode region. The modes that can be selected with this live key are: All: PM1, PM2.5, Resp. PM10 and Total IAQ-ENV: PM1, PM2.5 PM10 and Total IH: Resp., PM10 and Total
Run Mode Region	Shows the run mode selected from the RunMode screen.
File Name Region	Displays the file name to which the data is currently being saved.
Test Progress Region	Shows the time-based progress of the test.
Error Indicator	Shows the current stats of the instrument

8.0 ALARM

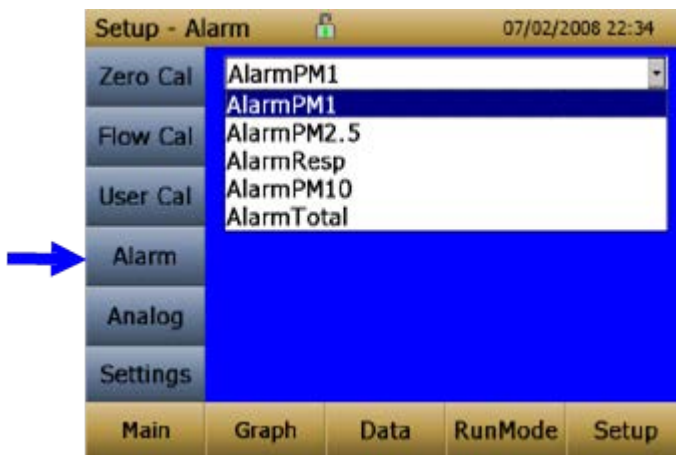

Alarm allows you to set alarm levels on any of the 5 mass channels PM1, PM2.5, RESP, PM10 and Total. However, the alarm functioning is determined by the logging interval. The alarm will turn ON only if the average concentration over the logging interval exceeds the set point. If the logging interval is too long and the concentration exceeds the set point and stays at that level, the alarm will not turn ON until after the logging interval has passed. Likewise, the alarm will not stop until after the concentration has dropped below 5% of the threshold and after the logging interval has passed.



The Alarm is dependent on the logging interval. For the DustTrak to alarm as soon as the Alarm Setpoint is exceeded, the logging interval must be set as low as possible (i.e., 1 second or 2 seconds). If long test durations do not permit setting such a short logging interval, use the STEL alarm instead. The STEL is always based on 1 second concentrations and is independent of the logging interval. For more details on the STEL alarm, see section below on STEL.

In Survey mode, the alarm is dependent on the time constant.

Alarm1 Setpoint [mg/m³]	The alarm1 setpoint is the mass concentration level upon which the alarm1 is triggered. Alarm will trigger if the mass concentration, taken at the logging interval, rises above the setpoint. <i>Note: Alarm 2 must be lower than Alarm 1 when both alarms are enabled.</i>
Relay1 [On, Off]	When the relay alarm is turned on, unit will close relay switch when Alarm1 level is surpassed. Relay alarm can only be linked to one mass channel at a time. Relay selection is available on the 8533 desktop model only.
STEL 1 [On, Off]	When the STEL alarm is turned on, STEL data will be collected when Alarm1 level is surpassed. STEL alarm can only be linked to one mass channel at a time. STEL selection is available on the 8533 desktop model only.
Alarm2 Setpoint [mg/m³]	The alarm2 setpoint is the mass concentration level upon which the alarm2 triggers. Alarm triggers if the mass concentration, taken at the logging interval, rises above the setpoint. <i>Note: Alarm 2 must be lower than Alarm 1 when both alarms are enabled.</i>
Alarm2 Enable [On, Off]	Enables Alarm2 to be logged and will activate the Audible or Visible alarms if they are enabled.

Audible [On, Off]	When the audible alarm is turned on, the instrument will activate internal beeper when Alarm1 or Alarm2 level is surpassed. Audible alarm can only be linked to one mass channel
Visible [On, Off]	When the visible alarm is turned on, unit will show the alarm icon (Alarm1  , Alarm 2 ) in title bar when Alarm1 or Alarm2 level is surpassed.

The STEL Alarm will be used for this project and will be set to **80% of the project-specific dust action limit**.

STEL Alarm

STEL stands for **Short Term Exposure Limit**. When a STEL alarm is selected, the instrument will inspect the data on a second by second basis, independent from the selected logging interval. If the mass exceeds the STEL limit, a STEL alarm triggers and the following actions will be taken.

STEL indicator	The STEL indicator will show Red on the main screen. 
Data	Data will be taken off the STEL alarm channel at a 1 minute logging interval for 15 minutes . This data will be stored in a separate file named STEL_XXX, where XXX will be matched to the logged data file. The instrument will also continue to log the mass concentration data at the logging interval selected.
STEL Alarm repeat	If the instrument remains over the STEL limit after the 15 minute interval, or if the instrument exceeds the STEL limit later during the sample period, additional STEL files will be generated.

9.0 MONITOR MAINTENANCE

The DustTrak DRX Aerosol Monitor requires maintenance on a regular basis. The table below lists the factory recommended maintenance schedule.

Some maintenance items are required each time the DustTrak monitor is used or on an annual basis. Other items are scheduled according to how much aerosol is drawn through the instrument. For example, TSI recommends cleaning the inlet sample tube after 350 hours of sampling a 1 mg/M³ concentration of aerosol. This recommendation should be pro-rated according to how the instrument is used. 350 hours at 1 mg/M³ is the same amount of aerosol as 700 hours at 0.5 mg/M³ or 175 hours at 2 mg/M³, etc.

Recommended Maintenance Schedule

Item	Frequency
Perform zero check	Before each use.
Clean inlet	350 hr. at 1 mg/m ³ *
Clean 2.5 µm calibration impactor	Before every use.
Replace internal filters	350 hr. at 1 mg/m ³ * or when indicated by the main screen filter error indicator.
Return to factory for cleaning and calibration (For 8533EP, TSI recommends that both the DustTrak monitor and the External Pump Module be returned to TSI)	Annually
Replace the internal HEPA filters in the External Pump module	Annually

*Pro-rated, see discussion above.

The DustTrak monitor keeps track of the accumulated amount of aerosol drawn through it since its last cleaning. When the internal filter replacement is due, the filter error indicator will turn from green to red.

Cleaning the Inlet

The inlet should be cleaned based on the schedule in Table 4-1.

1. Turn the DustTrak monitor off.
2. Unscrew the inlet nozzle from the instrument.



Unscrew Inlet Nozzle

3. Clean the inlet port. Use a cotton swab to clean the outside of the inlet port. The swabs can be dampened with water or a light solvent (e.g., isopropanol). Clean the inside of the sample tube by using a small brush, along with a light solvent. Dry the tube by blowing it out with compressed air, or let it air-dry thoroughly.



Do NOT Blow into Instrument

- a. Screw (hand-tighten) inlet back into instrument.

Replacing the Internal Filters

Replace the internal filters based on the schedule in Table 4-1 or when the filter indicator on the main screen changes to red.

1. Turn the instrument off.
2. Remove old filters from the instrument.

Desktop Model

- a. Open filter access door on the back of the instrument.
- b. Use the enclosed filter removal tool (PN 801668) to unscrew the filter cap.

- c. Pull out single cylindrical filter from filter well. If filter well is visibly dirty, blow out with compressed air.



Pull out Single Cylindrical Filter from Filter Well

- d. Put a new filter (P/N 801673) back into filter well and screw filter cap back into place.
- e. Open blue retention clip by pinching ends inward and pushing down.



Open Blue Retention Clip

- f. Remove 37-mm filter cassette by pulling downward and outward.



Remove 37-mm Filter Cassette

- g. Open filter cassette using enclosed tool PN 7001303.



Open Filter using Enclosed Tool

- h. Remove screen mesh from filter cassette and blow out using compressed air. Blow in reverse direction to remove captured particulate.
- i. Replace mesh in filter cassette and press halves together. Ensure filter has been fully closed. The filter tool PN 7001303 can be used to ensure the filter is fully closed.



Replace Mesh in Filter Holder

- j. Place filter cassette back into position and close blue retaining clip. Make sure retaining clip snaps back into place.

3. It is important to reset the instruments filter counter after replacing filters. Resetting the counter will clear the filter error condition shown on the main screen. Reset the counters by the following:
 - a. Turn on the instrument.
 - b. Press the Setup button to go into the setup screen.
 - c. Touch the Cum Filter Conc.: (live key) to reset the aerosol mass.

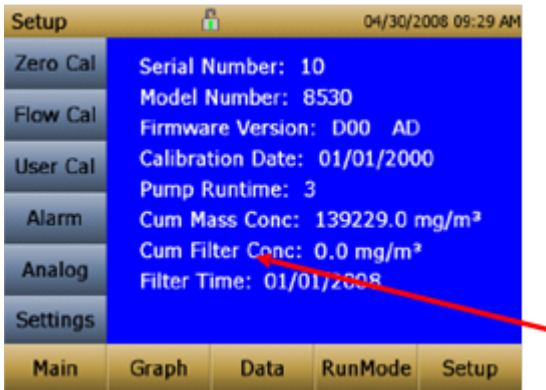

- d. *Replace user serviceable filters?* Dialog will appear. Press **OK**.
- e. *Reset filter concentration?* Dialog will appear. Press **Yes** to reset the cumulative filter concentration to zero.
- e. The Setup screen will not show zero for the **Cum Filter**.
- f. **Concentration** and the current date for the **Filter Time**.

10.0 CONTACTS

In the event you must reach ERM for any reason please use the following contact information:

Jeff Boggs - Field Project Manager

Mobile: (443) 803-8495
 Email: jeff.boggs@erm.com

Larry Hottenstein - QA Manager

Office: (949) 623-4700
 Mobile: (949) 294-9775
 Email: larry.hottenstein@erm.com

APPENDIX A

Field Data Sheet

Field Form Real Time Particulate Matter for ERM

DustTrak DRX Aerosol Monitor Model 8533

Pre-construction Air Monitoring Area 1, Phase 1 Development, Baltimore Works Site, Baltimore, MD

ERM WO 199768

Date

Field Technician (Print and Sign Name)

Others Present During Equipment Calibration, Operation or Maintenance? Provide Name(s)

Weather Observations (rain, dry, windy, etc.)

Photographs and any observed ambient conditions that may have potential to affect equipment operation or results?

Comments Regarding Site Security (appears secure, evidence of tampering, etc.)

Recommendations for Corrective Actions

Are PAM-1 and PAM-1 Duplicate connected to the same inlet?

Any evidence of power loss?

Jeff Boggs – Field Project Manager

Mobile: (443) 803-8495

Email: jeff.boggs@erm.com

Larry Hottenstein – QA Manager

Office: (949) 623-4700

Mobile: (949) 294-9775

Email: larry.hottenstein@erm.com

Darren Quillen – Project Manager

Office: (410) 972-0234

Mobile: (410) 991-9568

Email: darren.quillen@erm.com

Chuck McClellan – Field Technician

Office: (410) 972-4127

Mobile: (410) 937-7640

Email: charles.mcclellan@erm.com

Indicate if Recommended Maintenance Performed	Yes	No
Perform Zero Check before each use		
Clean Inlet at 350 hours at 1 milligram per cubic meter		
Clean 2 um calibration impactor before every use		

Calibration Using BIOS Defender 510-H						
Location ID	Serial ID	Start Time (24 hour clock)	Start Flow (Lpm)	End Time (24 hour clock)	End Flow (Lpm)	Photos of Start and End and Other Comments
PAM-1						
PAM-1 Duplicate						
OAM-1						
OAM-2						



Field Sampling Protocol and Standard Operating Procedure

Sampling of Hexavalent Chromium in Ambient Air

February 2014

Sampling of Hexavalent Chromium in Ambient Air

February 2014

Prepared by:

Environmental Resources Management

Air Measurements Group

3281 E. Guasti Rd. Suite 300

Ontario, CA 91761



TABLE OF CONTENTS

1.0 INTRODUCTION..... 1

2.0 EQUIPMENT LIST..... 1

3.0 HEALTH AND SAFETY 2

4.0 SAMPLE MEDIA AND RECEIPT FROM LABORATORY..... 2

5.0 SAMPLER APPARATUS, ASSEMBLY, AND INSTALLATION..... 2

5.1 BGI PQ100 APPARATUS..... 2

5.2 BGI PQ100 ASSEMBLY AND RETROFIT..... 4

5.3 BGI PQ100 INSTALLATION AT THE SAMPLE SITE 7

6.0 INITIAL SAMPLER SETUP AND PROGRAMMING..... 7

6.1 SAMPLE FLOW RATE SETTING 7

**6.2 SAMPLER DATE, TIME, TEMPERATURE, AND BAROMETRIC
 PRESSURE SETTINGS 9**

7.0 SAMPLE MEDIA INSTALLATION..... 11

**8.0 SAMPLER PRE-TEST FLOW VERIFICATION AND INITIATING A SAMPLE
 RUN 12**

8.1 PRE-TEST FLOW VERIFICATION 12

9.0 SAMPLE RECOVERY 14

**9.1 SAMPLE RUN ENDING AND FINAL FLOW VERIFICATION
 PROCEDURES..... 14**

9.2 SAMPLE REDEPLOYMENT..... 15

10.0 SAMPLE STORAGE, PACKAGING, AND SHIPPING..... 16

<i>11.0</i>	<i>QUALITY ASSURANCE/QUALITY CONTROL</i>	<i>17</i>
<i>11.1</i>	<i>FIELD BLANKS</i>	<i>17</i>
<i>11.2</i>	<i>TRIP BLANKS</i>	<i>18</i>
<i>11.3</i>	<i>FLOW RATE CALIBRATION</i>	<i>18</i>
<i>11.4</i>	<i>DAILY FLOW RATE VERIFICATIONS</i>	<i>18</i>
<i>12.0</i>	<i>SAMPLER MAINTENANCE</i>	<i>18</i>
<i>13.0</i>	<i>CONTACTS</i>	<i>18</i>

1.0 INTRODUCTION

This protocol and standard operating procedure (SOP) is intended to provide a general overview and step-by-step instructions for personnel in the field responsible for carrying out ambient air sampling for hexavalent chromium (CrVI). The instructions cover assembly of the sampler apparatus, sampler programming and operation, sample media preparation, deployment, sampling, monitoring/checking, field data recording, sample recovery, labeling, chain-of-custody procedures, and final shipping to the analytical laboratory.

This document assumes that sample location siting has already been successfully completed ensuring each location meets the acceptable criteria with regards to the proximity of obstructions (i.e. buildings, trees, etc.), technician safety, and any potential contamination contributions from surrounding operations.

2.0 EQUIPMENT LIST

The following equipment will be required for the sampling program:

- BGI Model PQ100 Sampler Kits Including:
 - PQ100 Sampler with firmware version 6.0 or 1.0M or higher
 - Tripod base assembly with legs
 - Downtube assembly
 - Retrofit kit from Eastern Research Group (ERG)
 - BGI flow adapter fitted with a stainless steel Swagelock union
 - ¼” Stainless steel U-tube
 - Pre-cleaned Teflon filter holder pre-charged with a pre-cleaned sodium bicarbonate impregnated cellulose fiber filter
 - Glass funnel inlet assembly
 - PQ101 battery charger/AC power supply
 - CQ2 PC Communication Adapter Cable
 - Flexible tubing for pump connection
- BGI tetraCal (formerly triCal) Calibrator unit (Note: Dry calibrators and rotometers are not recommended);
- Laptop PC with BGI software installed – software available for download at <http://www.bgiusa.com/aam/portable.htm>;
- Field data sheets/ chain-of-custody (COC) – provided in Attachment-A, clipboards, pens;
- Rigid coolers with ice packs - filters are to be kept at 0 °C or below at all times except during the actual sample periods;
- Secure, on-site freezer for temporary sample storage.

Additional Field Supplies:

- Miscellaneous tools (wrenches, screwdrivers, pliers, etc.);
- Hand-held GPS with extra batteries;
- Camera;
- Personal protective equipment (PPE), see the site specific Health and Safety Plan (HASP);
- Shipping supplies;
- Field notebook;
- Powder-free Nitrile gloves;
- Ziploc bags;
- Laser print label maker – hand printed labels are also acceptable.

3.0 HEALTH AND SAFETY

All sampling activities undertaken at the Site must be completed under an approved, site-specific HASP. The HASP identifies the hazards, personal protective equipment, monitoring, and emergency procedures for conducting work at the Site. Samplers and support personnel must acknowledge their review of the HASP prior to performing work at the Site.

4.0 SAMPLE MEDIA AND RECEIPT FROM LABORATORY

The sodium bicarbonate impregnated cellulose fiber filters will arrive pre-loaded into pre-cleaned Teflon filter holders from ERG eliminating the need for technicians to directly handle the filters both during pre-sampling setup and post-sampling recovery procedures. The filter holders will also arrive with a pre-cleaned glass funnel sample inlet assembly. The filter holders will arrive in a cooler with frozen ice packs and must be kept in the freezer until ready for deployment into the field.

The Teflon filter holders have inlet and outlet connections that accept ¼" OD tubing using Swagelok style compression fittings. Each filter holder will arrive with a Teflon plug inserted into both the inlet and outlet to seal against contamination until ready for deployment.

The glass funnel inlet apparatus will also arrive pre-cleaned from the laboratory and should remain sealed in its packaging until deployment into the field for sampling.

5.0 SAMPLER APPARATUS, ASSEMBLY, AND INSTALLATION

5.1 BGI PQ100 APPARATUS

The sampler used within this SOP is the Model PQ100 Air Sampler manufactured by BGI Incorporated. The unit employed during this program uses firmware version 6.0 or 1.0M or higher. The PQ100 uses a programmable pump and associated control logic that allows the unit to monitor its own air flow rate and adjust the pump speed to compensate for changes in load pressure and/or other forces that may affect the air flow rate. This allows the user to maintain a steady flow rate through the sample media throughout the sample duration. Figure 5-1 presents the typical PQ100 sampler and an example of installation on the tripod assembly. Figure 5-2 presents a simplified schematic of the PQ100 and associated process flow.

Figure 5-1. BGI PQ100 Sampler and Installation on Tripod Assembly



Figure 5-2. BGI PQ100 Sample System

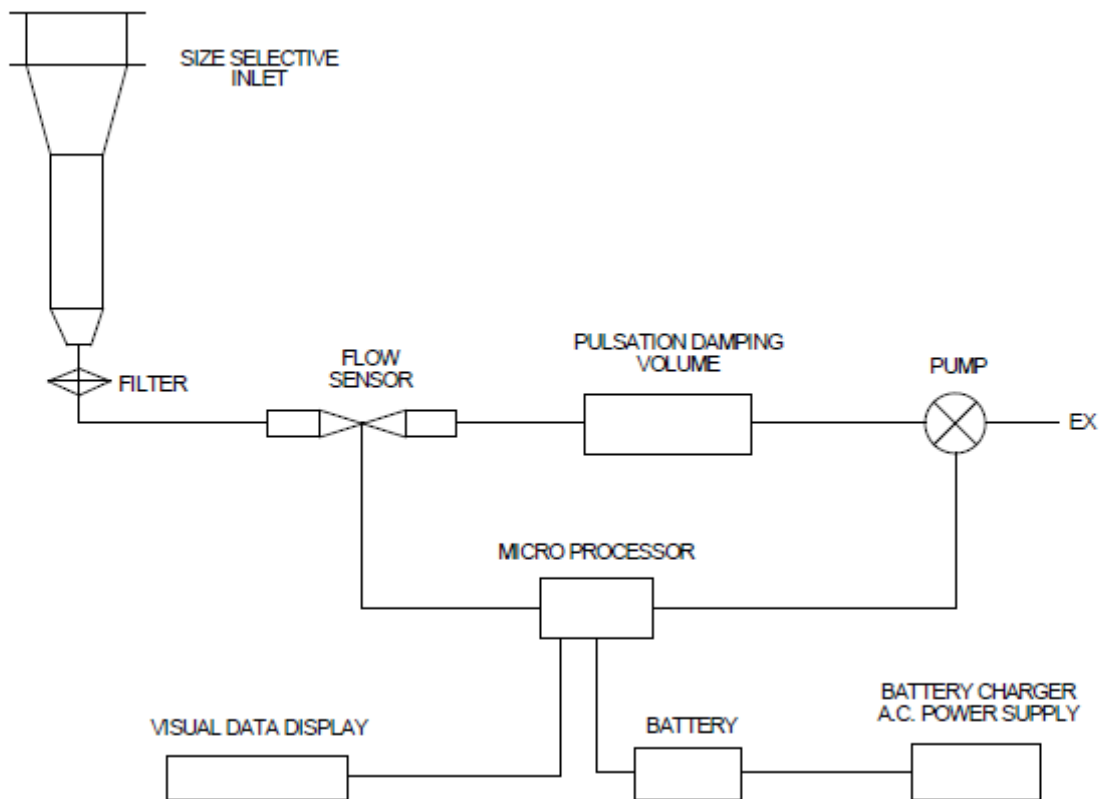

For purposes of this monitoring program, the PQ100 sampler will be operated without the particle size selector and filter holder shown in Figures 5-1 and 5-2. The sampler will be retrofitted with a custom apparatus supplied by ERG. The retrofit replaces the typical BGI F20 filter holder and particle sizing inlet with a section of stainless steel tubing used to attach a Teflon filter holder assembly and glass funnel inlet apparatus.

Air is drawn by the pump through the glass funnel sample inlet and through the sample media, into the stainless steel U-tube, through the downtube into the flow sensor. The signal generated by the sensor is then routed to a microprocessor which determines if the flow is at the set point value and adjusts the pump speed as necessary to maintain the correct flow rate. A pulsation damping volume has been incorporated into the unit to compensate for pulsation effects from the pump.

The PQ100 contains an internal 12-volt battery but can also be operated using an external 12-volt deep cycle battery. For purposes of this test program, AC power will be available for providing the sampler with constant power therefore the internal 12-volt battery will only be used to maintain sampler operation in the event sampling is interrupted by AC power loss.

5.2 BGI PQ100 ASSEMBLY AND RETROFIT

Refer to Figures 5-4 and 5-5 as well as the BGI PQ100 Instruction Manual and Quick Start Guide during assembly of the PQ100 sampler apparatus. The sampler will be assembled without the use of the particle size inlet (01), water jar (03), filter holder adapter (161), F20 filter holder, and brace (163) as shown in Figure 5-4 and will instead be fitted with the ERG retrofit apparatus as shown in Figure 5-5. The item numbers listed below in the following steps will refer to the Figure 5-4 schematic.

1. Unpack the instrument and legs checking the packing list against received items. Attach the legs (160) to the rigid base (11A) using attached knurled snap lock fittings.
2. Attach the downtube (162) onto the cylindrical base fitting in the rigid stand. The filter holder adapter (161) and F20 filter holder that typically go between the base and the downtube are omitted (See Figure 5-5).
3. Attach the flow adapter piece fitted with the stainless steel Swagelok fitting onto the top of the downtube. This piece is supplied by ERG specifically for this retrofit (See Figure 5-5).
4. Attach the stainless steel U-tube supplied by ERG to the Swagelok fitting on top of the flow adapter and tighten the nut. Make sure that the inlet to the stainless steel tubing is capped off until ready to attach the sample media to avoid potential contamination.
5. Set the PQ100 pump into the stand, screw in the hose adapter, and attach the flexible hose from the pump to the downtube base.
6. Attach the PQ101 battery charger/AC power supply to the PQ100 unit and place up inside the charger box and hook along the edge of box.

7. Plug the other end into standard 115-120 VAC, 15-amp power. If using an extension cord, ensure that the cord has been inspected and is in good operating condition with no cracks or frays of the insulation and uses a proper three-prong grounded plug. Protect the power connection (AC plug) from moisture and possible shorting by sealing the connection using nylon electrical tape. If possible, also place the connection in an area protected from weather such as beneath the sample platform (if so equipped). A plastic Ziploc bag sealed around the connection has also been used successfully.
8. It is recommended that the unit be plugged in for at least 24 hours prior to sample initiation to allow the internal battery to charge.

Figure 5-4. Standard PQ100 Assembly

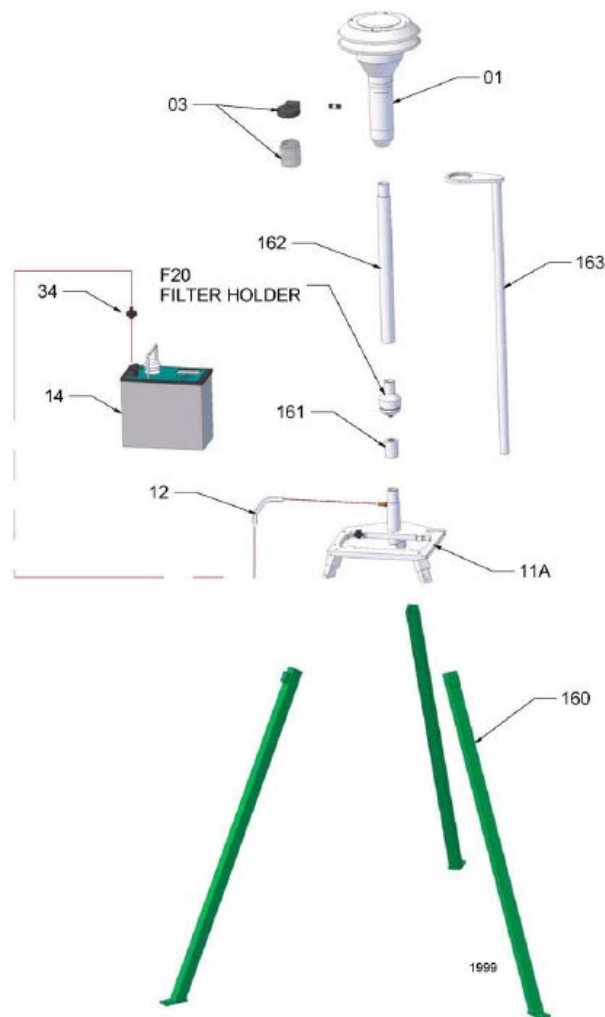

Note: The BGI particle size selector (01), water jar (03), filter holder adapter (161), F20 filter holder, and brace (163) will be omitted and replaced by the retrofit apparatus shown in Figure 5-5.

Figure 5-5. PQ100 Assembly with ERG Retrofit



5.3 BGI PQ100 INSTALLATION AT THE SAMPLE SITE

This document assumes that sample locations have already been sited and adhere to the proper sample location criteria. The sampler should be placed on a reasonably level surface with the sample inlet at a height of 2-15 meters (EPA-specified breathing zone). The height of the sample inlet should be appropriate as assembled but should be double-checked to ensure sampling no less than 2 meters above ground and with unobstructed air flow for at least 270 degrees around the sampler. For collocated sampling, each sampler should be placed at a distance of no less than 2 meters and no more than 4 meters from each other and have sample inlet heights that differ by no more than 1 meter (in most situations using collocated samplers the sample inlets will be at the same approximate height).

The samplers should be secured from the effects of wind loading to prevent tipping over in elevated wind conditions. Weighted wooden platforms have been used during prior test programs for adjusting the height of the sampler and securing the sampler firmly to the ground. Attaching 1' lengths of 2"x4" boards to the feet of the stand using lag bolts and securing with sandbags has also been used successfully.

6.0 INITIAL SAMPLER SETUP AND PROGRAMMING

6.1 SAMPLE FLOW RATE SETTING

The PQ100 may be delivered from the supplier with a default setting of 16.67 lpm based on the EPA standard. For purposes of this test program, the flow rate setting shall be 15.0 lpm. To set the flow rate to 15.0 lpm, choose the "Set Flow Rate" option in the main menu of the PQ100 and set the value to 15.0 lpm. After setting the flow rate, perform a calibration of the PQ100 following the calibration procedure outlined below using the tetraCal unit in direct or manual modes. Use a spare ERG filter assembly marked "calibration" for performing the flow setting and calibration. You will not use the glass funnel sample inlet for the initial flow calibration.

First ensure the PQ100 unit is set to "Volume Flow" under the "Select F Unit" menu title. See procedure below.

>Select Flow Rate Measurement

Flow rate may be controlled in two modes, either as Actual Flow which means the flow rate at the instantaneous Barometric Pressure and Ambient Temperature, in which case it is known as Q_A . Alternatively Standard flow may be selected. This is the flow rate at a set of standard conditions. In the case of the US EPA, Standard conditions (for PM10) are 25 C and 760 mm of Hg. This system is also referred to as Mass Flow.



```
Escape to Exit
Date and Time
Cal.: lpm.
Cal.: MP
+select Flow Rate
+select MP unit
+select F unit
Enter to Select
```

>Select F unit

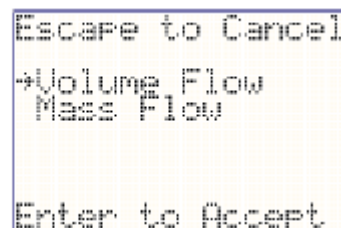

```
Escape to Cancel
+Volume Flow
Mass Flow
Enter to Accept
```

Attach the tetraCal unit to the inlet of the calibration filter holder assembly using an appropriate length of ¼” OD Teflon or polyethylene tubing. The tubing should fit directly into the filter holder inlet and be secured and sealed by tightening the nut. Attach the other end of the tubing to the tetraCal unit. You may need to use a piece of flexible rubber tubing to attach the ¼” Teflon tubing to the tetraCal inlet. Follow the instructions below as presented in the BGI PQ100 Instruction Manual to calibrate the PQ100 flow rate setting to 15.0 lpm. Record the calibration data in the field logbook.

7.0 CALIBRATION

7.1 Calibrate Flow rate:

The preferred way to calibrate the PQ100 is to use the tetraCal **Direct Cal** mode.

The tetraCal Direct Cal works as follows:

The tetraCal puts out a continuous stream of flow rate information in ascii format. When the tetraCal Direct Cal mode is selected on the pump menu (D:cal), the pump is instructed to look for the stream of flow rate data. It then compares the tetraCal flow rate data to it's own flow rate information and calculates an offset and then automatically adjusts the pump motor speed to match the data coming from the tetraCal.

At the Setup and Calibration Menu:

- 1) Scroll using the Up and Down buttons to the "Cal. Flow Rate" position. Press the Enter button to accept.

```

Escape to Exit
Date and Time
Flow Cal: lpm.
Flow Cal: lpm.
+Flow Cal: Flow Rate
Flow Cal: select BP unit
Flow Cal: select F unit
Enter to Select
    
```

At D:cal menu

Connect the Pump and calibrator using tubing and filter

- 1) Turn the tetraCal "ON" and allow it to zero, itself.
- 2) Using the Up and Down buttons, scroll to the "D:Cal" position and press the Enter button. The pump will automatically begin to run. At this point the pump instantaneously compares its data to the tetraCal data and calculates an offset.

```

Escape to Cancel
Manual
+D:cal
Reset
Enter to Select
    
```

- 3) When the flow readings on the PQ100 is stable press the "Enter" button.

```

Escape to Cancel
Calibration in Progress

Is D:cal
connected??
Press Enter
when stable
    
```

7.2 Manual Calibration

- 1) Using the Up and Down buttons, scroll to the "Manual" position and press the Enter button. The pump will automatically begin to run.

```
Escape to Cancel
+Manual
D'cal
Reset
Enter to Select
```

>Adjusting Flow:

- 1) Adjust the flow reading on the tetraCal or any other calibration device, to match the reading on the PQ100, using the Up and Down buttons. One button push is approximately equivalent to a change of 0.1 lpm. Either button may be held down to effect large changes.
- 2) Press the Enter button to accept the Calibration.

```
Escape to Cancel
Manual Cal.
16.67 LPM
up dn to match
flow meter
Enter to Accept
```

If the tetraCal unit is not available, then use of an equivalent flow rate standard is acceptable for calibrating the PQ100 in manual mode as outlined above. Note that piston-type dry calibrators and rotameters are not recommended as calibration standards for the PQ100.

6.2 SAMPLER DATE, TIME, TEMPERATURE, AND BAROMETRIC PRESSURE SETTINGS

Set the PQ100 to the correct date and time prior to use. Follow the procedure below for setting the sampler date and time.

>Making a Selection:

- 1) To select "Date and Time", scroll using the Up and Down buttons, then press the Enter button to accept.

```
Escape to Exit
+Date and Time
Date: 1/1/11
Time: 12:00
Cal: 1000
Flow Rate
Select BP Unit
Select F Unit
Enter to Select
```

Setting the Date and Time:

- 1) Move the (→) using the Up and Down buttons.
- 2) Press the Enter button to select the item. The item will then flash.
- 3) Use the Up and Down buttons to correct the numeric value. Press and hold to accelerate the speed of the numeric change.
- 4) Press the Enter button to accept the value and the (→) will automatically advance to the next item.
- 5) Select "Done" to return to the "Setup and Cal Menu".

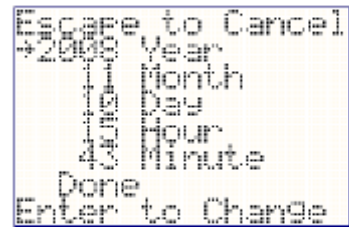

Escape to Cancel
→2008 Year
11 Month
10 Day
15 Hour
43 Minute
Done
Enter to Change

The tetraCal unit can be used to calibrate the temperature and barometric pressure of the PQ100 as well. These parameters should already be in calibration when received from the equipment supplier however if it is observed that the temperature and barometric pressure parameters are potentially out of calibration, follow the procedures below to calibrate these parameters using the tetraCal unit. Record any calibrations performed in the field logbook.

> Calibrate Temperature:

- 1) To select "Cal. Temp.", scroll using the Up and Down buttons, then press the Enter button to accept.



Escape to Exit
Date and Time
→Cal. Temp.
Cal. BP
Cal. Flow Rate
Select BP unit
Select F unit
Enter to Select

> Adjusting the Temperature

- 1) Compare the temperature reading from the PQ100 to a tetraCal or other standard.
- 2) If they differ, change the numeric value on the PQ100 using the Up and Down buttons.
- 3) Press the Enter button to accept the value and return to the "Setup and Cal Menu".

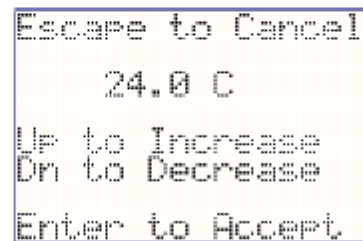

Escape to Cancel
24.0 C
Up to Increase
Dn to Decrease
Enter to Accept

>Calibrate Barometric Pressure:

- 1) To select "Cal. BP.", scroll using the Up and Down buttons, then press the Enter button to accept.

```
Escape to Exit
Date and Time
Cal: Temp.
→Cal: BP
Cal: Flow Rate
Select BP unit
Select F unit
Enter to Select
```

>Adjusting the Barometric Pressure

- 1) Compare the Barometric Pressure reading from the PQ100 to a tetraCal or other standard.
- 2) If they differ, change the numeric value on the PQ100 using the Up and Down buttons.
- 3) Press the Enter button to accept the value and return to the "Setup and Cal Menu".

```
Escape to Cancel
760 mm of Hg
Up to Increase
Dn to Decrease
Enter to Accept
```

7.0 SAMPLE MEDIA INSTALLATION

Follow the procedure below for installation of the filter holder containing the sample filter and sample inlet apparatus. Refer to Figure 5-5 for an example of the completed sampler unit.

- 1) Ensure that the sample media are delivered to the sample site within a cooler with ice packs to keep the filters cold and protected from the elements.
- 2) Prior to installation of the filter holder and glass funnel apparatus onto the PQ100 sampler, ensure that the sampler is free of dust and debris buildup. Wipe the sampler down with a damp cloth as appropriate.
- 3) Wearing powder-free nitrile gloves, remove the filter holder from its packaging. Note the filter ID (if so identified by the lab). If the filter is not marked with an identifying number, mark the filter holder packaging with an appropriate sample ID indicating sample location, day, and time. Record all sample media identification on the field data sheet. The field data sheet is included as an attachment to this SOP and is also used as the COC (Chain-of-Custody).
- 4) Mark the corresponding glass funnel inlet assembly packaging with the same identification parameters as the filter holder.
- 5) Loosen the nut on the filter holder outlet fitting and remove the Teflon plug. Store the Teflon plug in the filter holder packaging to protect it from contamination. Install the filter holder onto the end of the stainless steel U-tube by inserting the tubing into the filter holder outlet fitting and tightening the nut.
- 6) Leave the Teflon plug in the inlet side of the filter holder until ready to perform the initial flow rate verification.

8.0 SAMPLER PRE-TEST FLOW VERIFICATION AND INITIATING A SAMPLE RUN

The sample runs conducted during this test program will be initiated and terminated manually by the field technician. This eliminates the need for programming the PQ100 for pre-determined start/stop times and run durations. As such, procedures for programming pre-set start/stop times have been omitted from this SOP.

8.1 PRE-TEST FLOW VERIFICATION

A pre-test flow rate verification will be conducted following the installation of the filter holder assembly and prior to initiation of the sample run in order to ensure proper operation and flow rate of the PQ100. Following installation of the filter holder assembly onto the stainless steel U-tube, connect the tetraCal unit (or other primary flow standard) to the inlet of the filter holder as was done during the initial flow rate setting calibration. Follow the instructions below for performing the initial flow rate verification:

- 1) Manually start the PQ100 from the menu presented below by selecting the “Run Now” option.

>At the Main Menu:

- 1) Scroll using the up and down buttons to make a selection. Position the → in front of the selection and press the enter button.

→ Run Now	Initiates a sampling event.
→ Run Programmed	Setup and initiate a programmed sampling event.
→ Set Fcns/Cal	Setup Time, Units and calibration Functions.
→ Set Language	Choice of English or Spanish

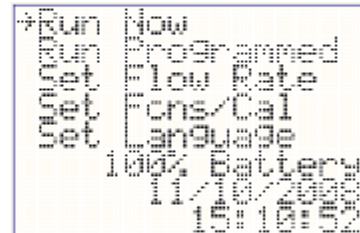

Note: Prior to using the PQ100, it is wise to set up the Date, Time and Preferences. Advance to the “Set Preferences” section of this manual.

- 2) Allow the unit to warm up for 5 minutes. The display should read the actual flow, standard flow, barometric pressure, and elapsed time as shown below.



- 3) After warm up, record the flow rate reading indicated by the tetraCal and the PQ100. The unit is acceptable if the flow rate indicated by the PQ100 is within $\pm 4.0\%$ of the flow indicated by the tetraCal unit.
- 4) Stop the pump by depressing the “Enter” button. See the example screenshot below.

6.2 Stopping the Run:

- 1) While the pump is running, press the “Enter” button, to stop the run.
- 2) The final run data will be displayed on the LCD.

Note: After the “Run”, pressing “ESC” will cause the elapsed run data to disappear. Pressing “ESC” will cause it to reappear. *Run information is not lost until overwritten by a new run.*

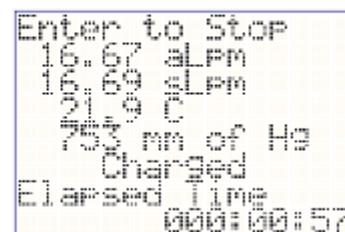

- 5) Detach the tetraCal unit at the filter holder inlet and replace the Teflon plug.
- 6) Wearing powder-free nitrile gloves, remove the glass funnel sample inlet assembly from its packaging (ensuring once again that the packaging has been appropriately labeled to correspond to the filter holder).
- 7) Loosen the nut on the filter holder inlet fitting and remove the Teflon plug. Store the Teflon plug in the filter holder packaging to protect from contamination. Install the glass funnel sample inlet assembly onto the filter holder by inserting into the inlet fitting of the filter holder and tightening the nut.
- 8) After installation of the filter holder and glass funnel inlet assemblies, the sampling run is ready to begin. Start the sampling run by depressing the “Enter” button to start the sample pump. The run data recorded by the PQ100 during the initial flow rate verification should reset once the new sampling run is started. Record all of the following parameters on the field data sheet:
 - Operator Name
 - Sample ID
 - Sample Location
 - Sampler Serial No.
 - Sample Start Date
 - Sample Start Time
 - Initial Elapsed Time reading (should be 00:00)
 - Ambient Temperature and Pressure (current instantaneous values)
 - Sample flow (aLpm and sLpm)
 - Note any unusual or notable activities in the area in the comments section
- 9) The sample event is now running. Operate the sampler for a period of 24 hours \pm 30 minutes. Repeat this procedure for each additional sample location making sure to stagger the start times of each sample location to allow enough time for the completion of recovery and re-deployment

procedures (presented below) at each location prior to the anticipated end time of the previous sample.

9.0 SAMPLE RECOVERY

9.1 SAMPLE RUN ENDING AND FINAL FLOW VERIFICATION PROCEDURES

Samples will be operated for a period of 24 hours \pm 30 minutes. Make sure to plan ahead in order to arrive at the sample locations in time to end the sample event while also allowing enough time for preparation of recovery and re-deployment procedures. Follow the instructions below for sample recovery and re-deployment:

- 1) After arriving at the sample location, ensure the sampler continued to operate normally throughout the sample period and that nothing has been disturbed. Note any issues encountered or potential disturbances on the field data sheet. Note also any unusual activities in the surrounding area.
- 2) Record the final sample flow rate (aLpm and sLpm) on the field data sheet. Stop the sample pump by depressing the “Enter” button as described above in item No. 4 of Section 8.1. The PQ100 screen will display the run parameters as indicated below.

Total volume is displayed as Actual volume or as Standard volume, corrected to sea level and Standard temperature. The information will alternately be displayed on the last line.



```
Escape to Clear
Run Completed:
S:05/05 14:52:30
E:05/05 14:54:15
Avg BP: 753 mm
Avg T: 21.9 C
Flow: 16.27 sLPM
StdVol: 28.5 L
```

- 3) Record the data on the field data sheet including:
 - a. Sample End Date
 - b. Sample End Time
 - c. Total Elapsed Sample Time
 - d. Ambient temperature and barometric pressure (current instantaneous values)
 - e. Average barometric pressure (on PQ100)
 - f. Average temperature (on PQ100)
 - g. Total sample volume (on PQ100)
 - h. Average flow rate
 - i. Total calculated standard volume
 - j. Note any unusual or notable activities in the area in the comments section
- 4) Wearing powder-free nitrile gloves, remove the glass funnel inlet assembly from the filter holder and place into the original packaging that has been properly labeled. Store in the sample media cooler with ice packs.

- 5) Attach the tetraCal (or other flow standard) to the inlet of the Teflon filter holder with the Teflon tubing used during the calibration and initial flow verification.
- 6) After ensuring all sample run data has been collected from the PQ100 unit, re-start the pump. As the unit had previously been running and was manually shut down after the end of the sample period, it should already be at or near operating temperature and therefore the warmup period will be minimal. Obtain the flow rate readout from the tetraCal unit after two minutes of warmup time. Record this data on the field data sheet under the final flow rate verification.
- 7) Disconnect the tetraCal unit from the inlet of the filter holder.
- 8) Replace the Teflon plug in the filter holder inlet and tighten the nut.
- 9) Remove the filter holder from the sampler by loosening the nut on the outlet fitting and removing from the stainless steel U-tube.
- 10) Replace the Teflon plug at the filter holder outlet and tighten the nut.
- 11) Per ASTM Standard D7614-12, Section 13.6, the following conditions will render the sample invalid:
 - a. Filters that are dropped or become contaminated with any foreign matter (dirt, finger marks, ink; or
 - b. Filters with tears or pin holes; or
 - c. Start and stop flow rates differ by more than 10%: or
 - d. Filter samples collected by the samplers which operated less than 23 hours or more than 25 hours; or
 - e. A power failure occurs during a sample run which causes the stop time or sample duration requirements to be violated; or
 - f. Filed blank fails if the concentration is higher than 3 times the method detection limit.
- 12) Ensure there is no excess dust or debris on the outside of the filter holder and return the sample into its packaging from the laboratory that was previously labeled. As soon as possible place the sample into the cooler with ice packs to maintain sample integrity during storage and shipping.
- 13) If sample run data is to be downloaded from the PQ100 unit, do so at this time using a laptop computer with the appropriate BGI software.

9.2 *SAMPLE RE-DEPLOYMENT*

If excessive dust or debris is observed on the sampler, use a damp cloth to wipe down the unit before proceeding to installation of sample media and initiation of the next sample run.

Following recovery of the sample at a particular location and any maintenance activities, prepare the next sample for deployment following the procedures outlined in the sections above. Install the filter holder, perform the initial flow rate verification, install the glass funnel sample inlet assembly, and initiate the sample run, recording all data as outlined in the previous sections. It is suggested that each location be recovered and re-deployed before moving on to the next sample location. Make sure to stagger the start times at each location during the program initiation to allow sufficient time to conduct recovery and redeployment procedures at each location while maintaining the ability to end sampling at each location at approximately the 24-hour mark \pm 30 minutes.

10.0 SAMPLE STORAGE, PACKAGING, AND SHIPPING

Once the samples from all locations have been recovered and new samples have been deployed, take the cooler containing the recovered samples to a clean location protected from the wind; a lab or office location is recommended. Follow the instructions below for storage and preparation for shipping.

- 1) Ensure that enough ice packs is available for keeping all of the samples cold during transport from the site and during shipping. Samples can be stored sealed in their packaging in the freezer until ready for shipping. The hold time for these samples is a maximum of 10 days.
- 2) The field data sheets filled out for each sample location are also to be used as the laboratory COC forms for each sample. Fill out the appropriate “Field Recovery” section with the relinquishing individual and date/time. Normally these data sheets will be provided by the laboratory in triplicate forms in which the original will remain with the samples during return shipping and the collector will keep the back copy. If however the forms are not provided as triplicate, make copies of all data sheets/COCs prior to sending with the samples. Original copies are retained and the copy will accompany the samples.
- 3) Line the bottom of the cooler with brown paper packing material then add a layer of ice packs. Do not use bubble wrap or foam packing peanuts as this tends to deplete the ice packs much faster than the paper material. Cover the ice packs with another layer of paper packing material.
- 4) Ensure each sample is sealed in its packaging from the laboratory. It is recommended that each sample be double bagged using plastic Ziploc bags. Ensure that each sample is properly labeled.
- 5) Place the samples into the cooler and fill in the gaps between samples with paper packing material. Place a layer of paper packing material over the samples. If desired, place more ice packs along the sides of the samples but remember to cover the ice packs with paper packing material to slow sublimation. Place enough packing material into the cooler so that the samples will not shift around during shipping.
- 6) Place the COC forms into a Ziploc bag and place these on top of the packing material inside the cooler. Seal the cooler with packing tape. It is not required, however, the use of a custody seal on the cooler is recommended to ensure sample integrity during shipping.
- 7) It is anticipated that samples will be shipped to the analytical laboratory in two batch shipments per week following the schedule outlined below.

Anticipated Sample Shipping Schedule:

<u>Shipping Day:</u>	<u>Samples Recovered on:</u>
Monday	Friday, Saturday, Sunday, Monday
Thursday	Tuesday, Wednesday, Thursday

- 8) Ship the samples to the analytical laboratory at the following address via priority overnight shipping (next day AM delivery):

Eastern Research Group
Sample Receiving
PM: Julie Swift
601 Keystone Park Drive
Morrisville, NC 27560
919-468-7924

11.0 QUALITY ASSURANCE/QUALITY CONTROL

11.1 FIELD BLANKS

Daily field blanks will be collected and submitted for analysis. Collect a field blank each day of sampling at one selected sample location following the procedures below:

- 1) The field blank must be collected prior to the installation of the actual sample media.
- 2) Using powder-free nitrile gloves remove a new pre-charged filter holder from its packaging and record the filter ID on the field data sheet as well as on the media packaging. Make sure to note in the sample log that this sample is a field blank.
- 3) Remove the Teflon plugs and install the filter holder onto the stainless steel U-tube as instructed in Section 7.0.
- 4) Do not perform flow verification on the field blank sample. Proceed directly to attaching the glass funnel sample inlet assembly to the filter holder.
- 5) After installation of the glass funnel inlet assembly, wait for 10 seconds to allow exposure then remove the glass funnel sample inlet assembly and filter holder.
- 6) Replace the Teflon plugs and place the filter holder and the sample inlet assembly into their respective packages and seal.
- 7) Place each component in the cooler with ice packs for transport from the site. Store the samples in the freezer until ready for shipping to the laboratory.

11.2 TRIP BLANKS

One trip blank will accompany each shipment of samples to the laboratory. Follow the instructions below to collect the trip blank:

- 1) Obtain a new pre-charged filter holder and glass funnel sample inlet assembly and identify them with an appropriate sample ID on both the sample packaging and the field data sheet/COC. Identify the units as trip blanks in the sample log.
- 2) Do not open the packaging and in no way expose the sample filter holder or glass funnel assembly.
- 3) After properly identifying each, place the filter and glass funnel assembly into the shipment for return to the laboratory. Two trip blanks will be sent each week corresponding to the two sample batches shipped each week.

11.3 FLOW RATE CALIBRATION

The sampler flow rate will be calibrated at 15.0 lpm prior to test program initiation using the manufacturers recommended flow rate standard (tetraCal) or other equivalent calibration standard (DeltaCal). Dry piston-type and rotameter flow standards are not recommended for the PQ100. The calibration will be checked monthly or sooner if it is suspected that the flow rate calibration has drifted.

11.4 DAILY FLOW RATE VERIFICATIONS

Sample flow rate will be checked prior to the initiation of sampling and at the end of each sample period. The average flow rate calculated will be coupled with the total elapsed sample time to determine the total sample volume. This value can also be compared to the total sample volume reported by the PQ100 for validation purposes.

12.0 SAMPLER MAINTENANCE

The samplers should require little to no maintenance with the exception of routine cleaning of excess dust and dirt buildup between sampling events. Pay attention to sampler operation looking for any abnormal noises and or behaviors. The sample pumps have a rebuild period of 5000 hours and since the units employed during this test program will be supplied from an equipment vendor, it is anticipated that each unit will be delivered in good operating condition with no overdue maintenance requirements. It is recommended that the operator check with the equipment vendor to ensure all sampler maintenance has been conducted and is up to date.

13.0 CONTACTS

In the event you must reach ERM for any reason please use the following contact information:

Jeff Boggs – Field Project Manager
Mobile: (443) 803-8495

Email: *jeff.boggs@erm.com*

Larry Hottenstein – QA Manager

Office: (949) 623-4700

Mobile: (949) 294-9775

Email: *larry.hottenstein@erm.com*

ATTACHMENT – A

Field Data Sheet and COC

Field Data Sheet

Site Identification: _____

Field Operator: _____

_____, Sampler #: _____

Set Up Date M TU W TH F SA SU

FRM Inlet Serial # _____

RUN # : _____

Run Date: M TU W TH F SA SU

Run Date: _____

Post- Sampling Information

Record sampler and site conditions below. Sample data is available from the *Review Last Run Data and Conditions screen.

Collected Filter ID: _____

Filter Condition: Normal Other _____

Elapsed Time (ET): _____

Total Volume: _____ (m3)

Error Flags (Circle): P Q F T M

AVG Flow Rate Q: _____ (Lpm)

CV: _____%

Tmax: _____ (°C)

Tmin: _____ (°C)

Tavg: _____ (°C)

BPmax: _____ (mmHg)

BPmin: _____ (mmHg)

BPavg: _____ (mmHg)

Comments:

FRM Service Information

Confirm performed tasks, and record all data. Work shall be performed as per the *Field Test Schedule*. The calibration standard shall be DeltaCal S/N 505.

Visually inspect the sampler o-rings, filter holder housing, electrical connections, and the internal water trap. Empty and clean the water collection jar as needed. Note any abnormalities: _____

External Leak Check Performed? <i>(Daily)</i>	YES / NO	Results:	PASS / FAIL	Initial _____ (cmH2O)	
				Final _____ (cmH2O)	
Internal Leak Check Performed? <i>(1/5 Samples)</i>	YES / NO	Results:	PASS / FAIL	Initial _____ (cmH2O)	
				Final _____ (cmH2O)	
Verified Ambient Temperature? <i>(1/5 Samples)</i>	YES / NO	Results:	Sampler Reading: _____ °C (A)	Standard Reading: _____ °C (A)	Acceptance Criteria <i>+/- 2.0 °C</i>
Verified Barometric Pressure? <i>(1/5 Samples)</i>	YES / NO	Results:	Sampler Reading: _____ mmHg	Standard Reading: _____ mmHg	Acceptance Criteria <i>+/- 10mmHg</i>
Verified Sampler Flowrate? <i>(1/5 Samples)</i>	YES / NO	Results:	Sampler Reading: _____ Lpm	Standard Reading: _____ Lpm	Acceptance Criteria <i>+/-2% (16.3/17.0 lpm)</i>
Verified Sampler Clock? <i>(1/5 Samples)</i>	YES / NO	Results:	Sampler Reading: _____	Standard Reading: _____	Acceptance Criteria <i>+/-1.0 minute</i>
Field Blank Installed? <i>(1/10 Samples)</i>	YES / NO	Filter ID:	_____		<i>If acceptance criteria are not met, calibration / adjustment of the sensor(s) is required.</i>

Sample Run Setup Information

Record the following information regarding the subsequent sample run. Use the **Run Sampler w/ User Defined Start/Stop* screen to schedule the event.

Installed Filter ID: _____

Start Date & Time: _____ Stop Date & Time: _____ Signature: _____



ERGM Research Group, Inc.

601 Keystone Park Drive, Suite 700, Morrisville, NC 27560

ERG Lab ID # _____

AMBIENT HEXAVALENT CHROMIUM CHAIN OF CUSTODY FORM

Lab Pre-Sampling	Site Code: _____	Collection Date: _____	
	City/State: _____	Primary Event (Y/N): _____	
	AQS Code: _____	Collocated Event (Y/N): _____	
	Relinquished by: _____	Date: _____	
Field Setup	Received by: _____	Date: _____	
	Site Operator: _____	System #: _____	
	Set-Up Date: _____	Elapsed Timer Reset (Y/N): _____	
	Collection Date: _____		
	Batch I.D. No.: _____		
	Initial Rotameter Setting (C.O. B.): _____	(After 5 minutes warm-up)	
	Programmed Start Time: _____	Programmed End Time: _____	
Field Recovery	Recovery Date: _____	Recovery Time: _____	
	Site Operator: _____		
	Final Rotameter Reading (C.O.B.): _____	(After 5 minutes warm-up)	
	Elapsed Time: _____	Status: Valid Void (Circle one)	
	Relinquished by: _____	Date: _____	
Lab Recovery	Received by: _____	Date: _____	Container #: _____
	Status: Valid Void (Circle one)		Temperature: _____
	If void, why: _____		
	Collection Time (Minutes): _____		
	Avg. Flowrate (L/min): _____		
	Total Volume of Air Sampled (m ³): _____		

Comments: _____

Appendix C
Laboratory Analytical Method SOPs



CONFIDENTIAL
Standard Operating Procedure
 Procedure Number: ERG-MOR-063
 Revision Number: 10
 Revision Date: February 20, 2014
 Page: 1 of 25

ENGINEERING AND SCIENCE DIVISION

TITLE: Standard Operating Procedure for the Preparation and Analysis of Hexavalent Chromium by Ion Chromatography		EFFECTIVE DATE: 2-20-2014
REFERENCES: ERG-MOR-013; ERG-MOR-033; ERG-MOR-034; ERG-MOR-042; ERG-MOR-097; CARB-039; Corporate Quality Management Plan; 40 CFR, Part 136, Appendix B; Dionex operations manual; ASTM Standard Test Method D7614		
SATELLITE FILES: LC Laboratory		
REASON FOR REVISION: Update MDLs and referenced ASTM Standard		
WRITER/EDITOR: NAME/DATE Randy Zowle 2/20/14	PROJECT MANAGER/TECHNICAL DIRECTOR: NAME/DATE Julie C. Swift 2/20/14	
QUALITY ASSURANCE COORDINATOR: NAME/DATE Domen Tedda 2/20/14	NEXT SCHEDULED REVIEW: 1/31/2015	

1.0 IDENTIFICATION AND PURPOSE

Chromium is a natural constituent of the earth's crust and present in several oxidation states. Trivalent chromium (Cr^{3+}) is naturally occurring, environmentally pervasive and a trace element in man and animals. Hexavalent chromium (Cr^{6+}) is generated anthropogenically from a number of commercial and industrial sources. Hexavalent chromium readily penetrates biological membranes and has been identified as an industrial toxic and cancer causing substance. Hexavalent chromium is a known inhalation irritant and associated with respiratory cancer and it is primarily associated with the chrome plating and anodizing process and emissions from chromate-treated cooling towers. This standard operating procedure (SOP) provides the analytical procedures for the analysis of Cr^{6+} with operation of the ion chromatograph (IC), Dionex-600.

2.0 MATRIX OR MATRICES

Hexavalent chromium has been measured in the air across the country. A procedure for sample preparation written by California Air Resources Board (CARB-039) has been

modified to the procedure listed below. The modified method was submitted and accepted as an ASTM Standard Test Method D7614 for the Determination of Total Suspended Particulate (TSP) Hexavalent Chromium in Ambient Air Analyzed by Ion Chromatography and Spectrophotometric Measurements. Sodium bicarbonate impregnated cellulose filters are exposed to ambient air using hexavalent chromium samplers designed, fabricated, and supplied by ERG (see SOP ERG-MOR-013 for sampling procedure).

3.0 METHOD DETECTION LIMIT

The method detection limit (MDL) is determined every year according to the procedure in 40 CFR, Part 136, Appendix B. A standard is spiked onto at least seven prepared filters at a concentration one to five times the estimated detection limit. These filters are extracted and analyzed according to the method outlined below. The Federal Register MDL equation is listed in Section 15.1. The method detection limit is 0.0078 ng/mL, which is 0.0036 ng/m³ (based on 21.6 m³ sample volume).

4.0 SCOPE AND APPLICATION

This procedure provides step-by-step instructions for analyzing hexavalent chromium collected on sodium bicarbonate-impregnated ashless cellulose filters exposed to ambient air.

5.0 METHOD SUMMARY

This SOP covers the determination of Cr⁶⁺ from sodium bicarbonate-impregnated ashless cellulose filters exposed to ambient air and submitted to the laboratory. The filters are extracted in a 20 mM sodium bicarbonate in deionized (DI) water solution via shaking for 45 minutes. The extract is analyzed by ion chromatography using a system comprised of a guard column, an analytical column, a post-column derivatization module, and a UV-VIS absorbance detector. In the analysis procedure, Cr⁶⁺ exists as chromate due to the near neutral pH of the eluent. After separation through the column, the Cr⁶⁺ forms a complex with the 1,5-Diphenylcarbazide (DPC) which can be detected at 530 nm. The analysis is completed using the Chromeleon® Client software version 6.50 SP4 Build 1000.

6.0 DEFINITIONS

AGP	Advanced Gradient Pump
CCB	Continuing Calibration Blank
CCV	Continuing Calibration Verification
CD	Compact Disc
cm	centimeter(s)

Cr ⁶⁺	Hexavalent Chromium
DC	Detector/Chromatography
DI	Deionized
DIUF	Deionized Ultra Filtered
DPC	1,5-Diphenylcarbazine
DVD	Digital Versatile Disc
g	gram
HPLC	High Performance Liquid Chromatograph
IC	Ion Chromatograph
ICV	Initial Calibration Verification
ICB	Initial Calibration Blank
LPM	liter(s) per minute
L	liter(s)
LCS	Laboratory Control Samples
mL	milliliter(s)
M	molar
MB	Method Blank
MDL	Method Detection Limit
mM	millimolar
MQO	Method Quality Objectives
ng/mL	nanogram(s) per milliliter
nm	nanometer(s)
PE	Performance Evaluation
PC	Post Column
PCR	Post-Column Derivatizing Reagent
RE	Relative Error
RSD	Relative Standard Deviation
SOP	Standard Operating Procedure
SP	Single Pump
μL	microliter(s)
μm	micron(s)
UV/VIS	Ultraviolet-Visible

7.0 INTERFERENCES

Sodium carbonate, used as the stabilizing medium in the Cr⁶⁺ filters, was observed to cause interferences with the analysis. Higher concentrations of the sodium bicarbonate impregnating solution may cause flow restrictions during the ambient air sampling. The use of an impregnated filter of smaller pore size has been shown to cause definite flow restrictions during sampling.

8.0 SAFETY

- 8.1 The IC does not require venting, and elaborate safety precautions are unnecessary. Safety glasses must always be worn in the laboratory. Gloves and lab coats are required during the handling of all hazardous solutions.
- 8.2 The compressed gas cylinders must be stored and handled according to relevant safety codes outlined in the corporate health and safety manual. The cylinders must be secured to an immovable structure. They must be moved using a gas cylinder cart.
- 8.3 Calibration standards are purchased in dilute solutions from certified vendors. Standard laboratory practices for hazardous material handling should be employed for handling acids, derivatizing reagents, and neat Cr⁶⁺ salts when these are used for analysis.

9.0 EQUIPMENT

This SOP assumes familiarity with the operation of Dionex ion chromatographic systems. For more detailed instructions in the operation of the Dionex IC, please refer to SOP (ERG-MOR-042) and the Dionex operations manual.

- 9.1 The Dionex ICS-5000 ion chromatography system consists of an AS-DV autosampler, an SP isocratic pump with seal wash, a DC chromatography compartment housing the injection valve, 1000 uL sample loop and IC columns, a PC-10 post-column reagent delivery device, and a VWD UV/VIS absorbance detector.
- 9.2 The Dionex-600 IC consists of an AS40 autosampler with chromatography compartment, a 1.0 mL sample loop for the AS40, a GP50 advanced gradient pump (AGP) with vacuum degas option, an eluent container set with rack, an eluent degas module, a LC20 chromatography enclosure, a Rheodyne injection valve (Model 9126-038), an AD25 UV/VIS absorbance detector, and a PC10 post-column pneumatic delivery package.
- 9.3 The instrument is controlled and data is collected and processed using the Chromeleon® Client chromatography software version 6.80 running on a computer using a Microsoft Windows operating system.

10.0 MATERIALS

- 10.1 47mm ashless cellulose filters, Whatman 41 or equivalent

- 10.2 Materials required for analysis include: waste containers and a helium regulator that regulates the pressure source for the post-column derivatizing solution and degassing of the eluents. Also, the specific guard and analytical columns are listed below in Section 14.2.
- 10.3 DIUF water for preparing eluent, post-column derivatizing reagent, sodium bicarbonate solutions, and standards.
- 10.4 Class A volumetric flasks: 10 mL, 100 mL, 200 mL, 500 mL, 1 L, and 2 L.
- 10.5 Wide-mouth high density polyethylene storage bottles: 125 mL.
- 10.6 Analytical balance, capable of 100 μg sensitivity.
- 10.7 Polystyrene tubes with caps and tube rack: 14 mL.
- 10.8 Ultrasonicator, to be used for standard preparation.
- 10.9 Glove boxes supplied with a screen rack and ultra-pure nitrogen to purge while handling and drying filters. One glove box should be designated as a filter preparation only glove box.
- 10.10 Graduated cylinders: 50 mL, 100 mL, and 500 mL.
- 10.11 4 Large plastic containers for rinsing filters and filter baths.
- 10.12 Freezers.
- 10.13 Teflon[®] coated or plastic tweezers for handling filters. Tweezers are cleaned with DI Water before use.
- 10.14 Pipettes: 100 μL , 5000 μL , and 10 mL.
- 10.15 Disposable nitrile gloves.
- 10.16 Autosampler vials and caps.
- 10.17 Wrist action shaker, to be used for sample preparation.

11.0 CHEMICALS, REAGENTS, AND STANDARDS

11.1 Eluent Solution

A standard eluent solution of the following reagents is prepared in deionized water:

- 250 mM ammonium sulfate, 99.99% purity trace metals basis
- 50.9 mM ammonium hydroxide, ACS reagent grade

In a 2 L volumetric flask, dissolve 66 g of ammonium sulfate in ~1 L DI water. Sonicate ammonium sulfate and water. When mixed, add 7 mL of ammonium hydroxide. Dilute to 2 L with DI water and sonicate briefly. The solution can be used for up to 5 days, but loses strength over the course of several days.

11.2 Post-column Derivatizing Reagent (PCR)

In a 50 mL volumetric flask, dissolve 0.25 g of 1,5-diphenylcarbazide (DPC), 97% purity, in HPLC-grade methanol. Sonicate until DPC goes into solution. In a 500 mL volumetric flask add DI water, leaving room for 14 mL of 98% sulfuric acid and 50 mL of DPC solution. Add 14 mL of 98% sulfuric acid and allow the solution to cool. Add the DPC solution to the 500 mL flask. Fill to the mark with DI water. Sonicate the solution briefly. This reagent is stable for three days. To minimize waste it should be prepared in 0.5 L or 1 L quantities as needed.

11.3 Sodium Bicarbonate Impregnating Solution

In a 500 mL volumetric flask, add 5.0 g of sodium bicarbonate. Dilute to 500 mL with DI water. Sonicate to mix.

11.4 20 mM Sodium Bicarbonate Solution

In a 2 L volumetric flask, add 3.36 g of sodium bicarbonate. Dilute to 2 L with DI water. Sonicate to mix.

11.5 Primary and Secondary Stock Solutions

Two stock solutions should be prepared and/or obtained from separate sources. The primary is to be used exclusively for the calibration standards and the secondary for laboratory control samples (LCS) and calibration verification.

11.6 Working Stock Solutions

The working stock solutions are 1000 ng/mL Cr⁶⁺. Working stock solutions should be prepared for both calibration standards and laboratory control samples/calibration verification. It is important not to use the same primary stock solution for both working stock solutions.

11.6.1 Calibration Working Stock Solution: Dilute the appropriate volume of the calibration primary stock solution to 100 mL using the 20 mM sodium bicarbonate in DI water solution.

11.6.2 LCS Spike Solution (Working Stock): Dilute the appropriate volume of the laboratory control primary stock solution to 100 mL using the 20 mM sodium bicarbonate in DI water solution. The LCS Spike solution is used to spike laboratory control samples and to make the calibration verification solution.

11.7 Calibration Standards

The six calibration standards are prepared by diluting the calibration working stock solution to the concentrations specified below.

11.7.1 0.05 ng/mL Cr⁶⁺ - Dilute 10 µL of the working stock solution to 200 mL using the 20 mM sodium bicarbonate solution.

11.7.2 0.1 ng/mL Cr⁶⁺ - Dilute 10 µL of the working stock solution to 100 mL using the 20 mM sodium bicarbonate solution.

11.7.3 0.2 ng/mL Cr⁶⁺ - Dilute 20 µL of the working stock solution to 100 mL using the 20 mM sodium bicarbonate solution.

11.7.4 0.5 ng/mL Cr⁶⁺ - Dilute 50 µL of the working stock solution to 100 mL using the 20 mM sodium bicarbonate solution.

11.7.5 1.0 ng/mL Cr⁶⁺ - Dilute 100 µL of the working stock solution to 100 mL using the 20 mM sodium bicarbonate solution.

11.7.6 2.0 ng/mL Cr⁶⁺ - Dilute 200 µL of the working stock solution to 100 mL using the 20 mM sodium bicarbonate solution.

11.8 Calibration Verification Solution

As part of the quality assurance program in the evaluation of the data, a calibration verification from a secondary source at an intermediate concentration

(0.5 ng/mL) is run as a check of the precision of the instrument and calibration. An Initial Calibration Verification (ICV) is run immediately following the calibration standards and Continuing Calibration Verifications (CCV) are run after every 10 injections.

- 11.8.1 Calibration Verification Solution Preparation - Dilute 50 μ L of the LCS Spike Solution to 100 mL using the 20 mM sodium bicarbonate solution.

12.0 COLLECTION, PRESERVATION, SHIPMENT, AND STORAGE

12.1 Handling of Filters

Whenever the filter is handled, clean Teflon[®] coated or plastic tweezers are used with disposable nitrile gloves. All filter drying and spiking is completed in the laboratory nitrogen-purged glove box.

Note: For normal ambient air samples, gloves do not need to be replaced while handling filters during extraction. For high particulate loaded filters, the analyst needs to be aware of potential contamination and gloves should be replaced if needed.

12.2 Preparation of Filters

- 12.2.1 Soak filters in a 10% nitric acid (50 mL of 70% nitric acid in 450 mL DI water) bath for a minimum of 16 hours and a maximum of 24 hours. New nitric acid solution is prepared before cleaning each filter batch. About 50 filters can be soaked per half liter of solution.
- 12.2.2 Rinse filters thoroughly with DI water until the pH of filter matches the pH of the DI water (about 30 minutes).
- 12.2.3 Dry the filters completely on a screen rack in a nitrogen-purged glove box (minimum of 5 hours). The filters will become stiff after they have dried.
- 12.2.4 Soak the filters in the impregnating solution (0.12 M sodium bicarbonate in DI water) overnight. If the filters are not completely dry before placing them in the impregnating solution, the solution will become dilute and will not collect samples as efficiently.
- 12.2.5 Dry the filters completely on a screen rack in a nitrogen-purged glove box until filters start to curl (minimum of 5 hours).

12.2.6 Place dried filters into petri dishes. Place the petri dishes into small plastic freezer bags labeled with the batch number and store in a freezer until needed.

12.2.7 Analyze 10 percent of the cleaned filters. If there are any detects above the MDL, the whole batch is discarded and a new batch is prepared.

12.3 Preservation and Storage of Filters

The filters are kept in the freezer until needed in the field for sampling or used in the laboratory to prepare spikes or blanks during analysis. The filters are frozen to prevent the sodium bicarbonate from reacting with possible interfering substances present in the air.

12.4 Cleaning Filter Holders

Clean the filter holders between sample collection by placing used holder parts into a container. Fill the container with DI water and agitate the filter holders. Discard DI water and repeat two times. Fill the container with DI water and sonicate the filter holders for one hour. Air dry filter holders completely before reuse.

12.5 Shipment of the Filters

Place filters in filter holder cartridges and tighten. Place in plastic freezer bags and place this into a labeled plastic can with funnel. The filter batch number is recorded on the chain of custody, and the chain of custody is put with the plastic can into a cooler packed with silver ice packs to keep the filters frozen. The coolers are shipped to the field approximately 1-2 weeks in advance. The filters are kept in freezers in the field until the sampling event.

12.6 Sample Hold Time

Stability of samples after sampling has been tested to 21 days. Samples should be extracted and analyzed within 21 days of sampling.

13.0 CALIBRATION AND STANDARDIZATION

13.1 Prepare calibration standards at a minimum of five levels as described in Section 11.7. The initial calibration ranges from 0.05 to 2.0 ng/mL Cr⁶⁺.

13.2 Analyze each calibration standard and tabulate the area response against the concentration injected. Follow the analytical procedures described in Sections 14.2. Use the results to prepare a calibration curve.

- 13.3 Use a Least Squares Linear Regression Calculation (Chromeleon® Client chromatographic software) to calculate the correlation coefficient, slope, and intercept of the regression. A correlation coefficient of at least 0.995 is required. A relative error (RE) between the concentration calculated using the regression line and the theoretical concentration of each calibration standard of < 20% is acceptable. See equation in Section 15.4. The regression is expressed as follows:

$$y = mx + b$$

where:

y = dependent variable (response)

m = slope of regression line

b = intercept

x = independent variable (concentration)

- 13.4 The Calibration Verification solution is used to verify the calibration at the beginning and throughout the sequence. Analyze an ICV after the initial calibration and analyze a CCV after every 10 injections, and at the end of the analysis batch. The primary stock solution for the ICV and CCV must be from a different source than what is used for the calibration standards. The recovery criteria are 85-115%. If the ICV or CCV is not within 15% of the target concentration, prepare a new Calibration Verification solution and/or recalibrate the instrument.

14.0 PROCEDURE

14.1 Filter Extraction

Due to the oxidation/reduction and conversion problems of Cr^{3+} and Cr^{6+} , the extraction should be performed immediately prior to analysis. It is important that the ion chromatograph be equilibrated, calibrated and ready for analysis. Prepare one cleaned, unused filter for every 20 filter samples in an extraction batch. Unused, clean filters will also be used to prepare duplicate blank spikes for every 20 filter samples in an extraction batch. See section 16.5.

- 14.1.1 Remove the exposed filter from the petri dish, using tweezers and disposable nitrile gloves. Fold the filter, place it in a 14 mL polystyrene test tube and add 10 mL of the 20 mM sodium bicarbonate in DI water solution. Cap the tube tightly. New tweezers should be used for each filter.

- 14.1.2 Place the tubes in a test tube rack. Place the tubes into the shaker for 45 minutes.
- 14.1.3 After 45 minutes of shaking, remove the tubes and put 5 mL of the sample extract into a to a 5 mL Dionex autosampler vial. Store the remaining extract in a refrigerator until analysis of all samples are complete. Store sample extracts in the refrigerator for up to one week, then transfer extracts to a labeled plastic bag and place in the fume hood in the laboratory for disposal.

14.2 Sample analysis

The analysis time is approximately 10 minutes. The following conditions are used for analysis.

- 14.2.1 Guard Column - IonPac NG1.
- 14.2.2 Analytical Column - IonPac AS7, 4 x 250 mm.
- 14.2.3 Eluent flow rate - 1.0 mL/min (250 mM ammonium sulfate and 50.9 mM Ammonium hydroxide).
- 14.2.4 Post column Reagent flow rate - 0.3 mL/min (2 mM DPC in 10% methanol and 1 N sulfuric acid).
- 14.2.5 Detection Wavelength - 530 nm.
- 14.2.6 Sample Volume - 1000 μ L.

15.0 CALCULATIONS

The Chromeleon[®] Client chromatography software calculates sample concentrations based on the calibration values entered into the program. These values are verified by a peer reviewer after analysis, and corrections can be made before reporting.

15.1 Method Detection Limit (MDL)

The MDL is determined every year according to the procedure in 40 CFR, Part 136, Appendix B. A standard is spiked onto at least seven prepared filters at a concentration one to five times the estimated detection limit. These filters are extracted and analyzed according to the method outlined. The method detection limit is 0.0078 ng/mL, which is 0.0036 ng/m³ (based on 21.6 m³ sample volume).

The MDL is calculated as follows:

$$\text{MDL} = (t) \times (\text{SD})$$

Where:

t = Student's t value for a 99% confidence level and a standard deviation estimate with n - 1 degrees of freedom [t = 3.14 for seven replicates]

SD= standard deviation of the replicate analysis

15.2 Calculation of Stock Standard Concentration

The concentration in ng/mL is calculated below:

$$\text{Stock Concentration} = \frac{(\text{Volume Stock Added } (\mu\text{L}) \times \text{Working Standard } (\text{ng} / \text{mL}))}{\text{Total Volume } (\text{mL})} \times \frac{1(\text{mL})}{1000(\mu\text{L})}$$

15.3 Calculation of Calibration and Check Standard Concentration

The concentration in the calibration, check standard and method spike standards is calculated below:

$$\text{Cal Std Conc.} = \frac{(\text{Volume Stock Added } (\mu\text{L}) \times \text{Stock Concentration } (\text{ng} / \text{mL}))}{\text{Total Volume } (\text{mL})} \times \frac{1(\text{mL})}{1000(\mu\text{L})}$$

15.4 Calculation of Least Squares Linear Regression Calibration Curve

Use a Least Squares Linear Regression routine (using Chromeleon[®] Client chromatography software) to calculate a correlation coefficient, slope, and intercept. Use concentration as the X-term (independent variable) and response as the Y-term (dependent variable).

15.5 Calculation of the Coefficient of Correlation

The correlation coefficient, R, is the square root of R² where:

$$R^2 = \frac{\left[\sum (XY) - \frac{\sum (X)\sum (Y)}{n} \right]^2}{\left[\sum (X^2) - \frac{(\sum X)^2}{n} \right] \left[\sum (Y^2) - \frac{(\sum Y)^2}{n} \right]}$$

15.6 Calculation of the Concentration of Cr⁶⁺ in Sample

The concentration in the sample is calculated below:

$$\text{Conc. Cr}^{6+} \text{ In Sample (ng/mL)} = \frac{(\text{Sample Response} - \text{Intercept})}{\text{Slope}}$$

15.7 Calculation of ICV and CCV Percent Recovery

The ICV and CCV percent recovery is calculated below:

$$\frac{[\text{Conc. Cr}^{6+} \text{ in Std.}] \times 100}{\text{Expected Conc.}}$$

15.8 To calculate the concentration of Cr⁶⁺ in the air sampled, the volume of air sampled must be known.

$$\text{Cr}^{6+} \text{ Concentration (ng/m}^3\text{)} = \frac{\text{RA (ng/mL)} \times \text{V}_2 \text{ (mL)}}{\text{V}_1 \text{ (m}^3\text{)}}$$

where:

RA	=	Concentration of Cr ⁶⁺ in analyzed sample
V ₁	=	Volume of air sampled
V ₂	=	Total volume of sample extract

15.9 Calculation of Laboratory Control Sample Recovery

Percent recoveries of the LCS and LCS duplicates are calculated as follows. First, the concentration of Cr⁶⁺ in the LCS is calculated as described in Section 15.5. The corrected weight of Cr⁶⁺ is divided by the amount of Cr⁶⁺ spiked and multiplied by 100 as shown below:

$$\% \text{ Recovery} = \frac{(\text{Actual Concentration of Cr}^{6+} \text{ in LCS}) \times 100}{\text{Theoretical Conc. of Cr}^{6+} \text{ in LCS}}$$

15.10 Calculation of Relative Error (RE)

$$\% \text{ RE} = \frac{(\text{Theoretical Conc.} - \text{Actual Conc.}) \times 100}{\text{Theoretical Conc.}}$$

16.0 QUALITY CONTROL

The analyst must perform the quality control checks listed in Table 24-1 and meet the requirements in this section. Method Quality Objectives (MQO) and data assessment criteria are determined from the results of the quality control samples. The MQO criteria are presented in Table 24-1. A data QC review check sheet is presented in Table 24-2.

16.1 Sample Collection Quality Control

The sample acceptance criteria for the filters are given below. All samples being logged in from the field are checked for these criteria. If a sample does not meet these criteria, the sample is invalid.

- 16.1.1 Filters dropped or contaminated with any foreign matter (i.e., dirt, finger marks, ink, liquids, etc.) are invalid.
- 16.1.2 Filters with tears or pinholes which occurred before or during sampling are invalid.
- 16.1.3 Sample flow rate:
 - If the average flow rate is less than 9.0 LPM or exceeds 16 LPM the filter is invalid.
 - If the start and stop flow rates differ more than $\pm 10\%$ the filter is invalid.
- 16.1.4 Filter samples collected by samplers which operate less than 23 hours or more than 25 hours are invalid.
- 16.1.5 If a power failure occurs during a sample run which causes the stop time or sample duration requirements to be violated, the sample is invalid.

16.2 Initial Calibration

Run a calibration curve with a minimum of five points as described in Section 13.0 at the beginning of each sequence and whenever the Calibration Verification standard does not fall within 15% of the target concentration. The

initial calibration range is from 0.05 to 2.0 ng/mL of Cr⁶⁺. Calculate a correlation coefficient. If the correlation coefficient is less than 0.995 or RE is greater than 20%, identify the cause and correct it. Repeat the calibration if necessary, or prepare and reanalyze any outlying points on the calibration curve.

16.3 Initial Calibration Verification/Continuing Calibration Verification

Analyze Initial Calibration Verification (ICV) after the calibration. Analyze a Continuing Calibration Verification (CCV) after every 10 injections and at the end of the sequence to verify instrument calibration. If the calibration check response is not within 15% of expected concentration, determine the cause. The instrument may be malfunctioning, the calibration verification standard may not be valid, or the instrument may need to be recalibrated.

16.4 Initial Calibration Blank/Continuing Calibration Blank

Analyze an initial calibration blank (ICB) prepared from the 20mM sodium bicarbonate solution after the initial calibration and ICV. Analyze a continuing calibration blank (CCB) after every CCV and at the end of the sequence to verify that no contamination is occurring during the analysis. The acceptance criterion is less than or equal to the MDL.

16.5 Laboratory Control Sample (LCS)

To ensure there are no matrix effects from the filters, prepare duplicate Laboratory Control Samples for every extraction batch, up to a maximum of 20 samples per batch. Spike 10 µL of the LCS spike solution onto an unused, cleaned filter, dry the filter in the nitrogen-purged glove box, and prepare and analyze the filter with the rest of the samples. The acceptance criterion is 80-120% recovery. If the spikes are outside of these limits, check the calibration and extraction procedures. These can also be referred to as Method Spikes.

16.6 Method Blank Sample (MB)

Prepare a method blank sample with every extraction batch by extracting a blank filter with 20 mM sodium bicarbonate solution. The acceptance criterion is less than or equal to the MDL.

16.7 Replicate Analysis

Replicate analyses should be performed on all duplicate or collocated samples received by the laboratory. The replicate results should be within 20% of each other for samples greater than 5 times the MDL. If the replicate results are outside of these limits, verify that the peaks are integrated properly, that there is

no interference from other components in the sample and that the instrument is working properly, and then flag the data.

16.8 Method Detection Limit

The method detection limit (MDL) is described in Section 15.1

16.9 Retention Time

The retention time must be within 5% of the expected retention time in order for a peak to be identified as Cr^{6+} . The expected retention time is the average retention time of the calibration standards. If retention times vary by more than 10% from calibration verification sample to calibration verification sample, stop the analysis and check for an instrument problem. If the retention time changes from the beginning of the day to the end of the day, the system may be changing over the course of the day.

16.10 Performance Evaluation (PE) Samples

Performance evaluation samples should be obtained as available from independent sources and analyzed as a routine samples.

16.11 Initial Demonstration of Capability

Each analyst must demonstrate proficiency for sample preparation and analysis by generating data of acceptable accuracy and precision for four blank spikes (or MDLs). For demonstration of capability, acceptable accuracy and precision is defined as having both a %RSD equal to or lower than 20% and a percent recovery within the range of 70-130%. This demonstration is repeated whenever new staff receives training or significant changes in instrumentation are made.

16.12 Control Charts

16.12.1 Retention Time

Chart the Cr^{6+} retention time for each calibration verification standard, laboratory control sample, and sample that contains Cr^{6+} . The retention time should not vary by more than 5% of the expected retention time. The expected retention time is the average retention time of the six calibration standards. If the retention time is out of this range check the column, check the mobile phase delivery system for leaks or plugs, and make sure the sample valve is properly aligned. Retention time control charts should be created for each sequence and kept in a notebook.

16.12.2 Laboratory Control Samples

Chart the LCS concentrations. The analyzed LCS concentration should not vary by more than 20% of the expected concentration. If the LCS concentrations are outside of these limits, check the calibration and extraction procedures. LCS control charts should be created for each column used and kept in a notebook.

16.13 Field Blanks

Prepare and ship Field Blank samples at least 10 percent sample collection frequency. Extract the Field Blank sample to verify cleanliness of the filters and filter holders. The acceptance criterion is less than or equal to the MDL. If results are greater than the MDL, another Field Blank sample is submitted to the field. All data associated with that blank (samples recovered between clean blanks) are flagged.

17.0 PREVENTION

When possible, minimize the amount of chemicals used in the preparation and analysis of the Cr⁶⁺ filters to reduce waste.

18.0 DATA REVIEW AND CORRECTIVE ACTION

18.1 Data Review Documentation

Project files including at a minimum the information required in Section 22 are assembled by the performing analyst. Documentation for sample custody, preparation and analysis will be reviewed for completeness and acceptability by the Task Lead or secondary reviewer associated with the project or program requiring the analysis as described in this section.

The second review of the data is performed by the Task Lead or designated secondary reviewer using the QC review checklist (checklist) shown in Table 24-2 to confirm that quality requirements have been met. Corrections and flags are added to the data consistent with the corrective action required for each review finding. Second level reviewers must complete, initial, and date the checklist.

The completed check list is included as part of the data package. Data not meeting SOP requirements are flagged and brought to the attention of the Project Manager for resolution.

18.2 Quality Staff Review

A minimum of 10% of the data is reviewed by ERG Quality Staff. Quality staff review includes but is not limited to checks that all SOP-specified quality parameters have been met and that data reviewers have completed their review checklists. Reviews should be documented on the review form initiated in 18.1 by the primary data reviewer. Comments or issues with data identified by the Quality Staff reviewer are brought to the attention of the Project Manager for resolution. Quality Staff will use the review process as an indication of episodic or systematic quality program issues that may require improvements to the ERG laboratory quality system and or additional training for ERG staff. As an option, Quality Staff may request review of 1% of the data from this method for a project. One percent (1%) review will follow the guidance in this section.

Corrective action for Hexavalent chromium analysis data quality issues are presented in Table 24-1.

19.0 WASTE MANAGEMENT

Hazardous waste disposal is discussed in detail in SOP ERG-MOR-033.

- 19.1 The PCR waste should be placed in an appropriately labeled waste container in the fume hood in the laboratory.
- 19.2 In the laboratory there should be a satellite hazardous waste container for the hexavalent chromium working standards and instrument waste.
- 19.3 The analyst is responsible for contacting the hazardous waste contact to dispose of the waste.

20.0 MAINTENANCE

20.1 Periodic Maintenance

For regular periodic maintenance, see Dionex-600 manual, Section 4. Any maintenance performed should be recorded in the maintenance logbook in the lab.

- 20.1.1 Inspect for leaks. Wipe up any liquid spills and rinse dried reagents off with deionized water.
- 20.1.2 Replace the eluent filter when changing eluents (see Dionex-600 manual, Section 4). The pump must then be primed to remove air in the eluent line.

- 20.1.3 Rinse the PCR line and container with methanol when the instrument is not in use for more than 3 days.

21.0 SHORTHAND PROCEDURE

- 21.1 Prepare filters.
- 21.2 Send filters to site.
- 21.3 Receive filter samples.
- 21.4 Inspect filter samples.
- 21.5 Place filters in an extraction tube.
- 21.6 Add 10 mL of 20 mM Sodium Bicarbonate in DI water solution to the extraction tube.
- 21.7 Shake for 45 minutes.
- 21.8 Calibrate the IC.
- 21.9 Analyze the extracts by IC.

22.0 DOCUMENTATION AND DOCUMENT CONTROL

- 22.1 All information concerning sample preparation, standard preparation, instrument conditions, etc., must be written in the analyst's notebook or recorded in the LIMS.
- 22.2 A list of the injections must be recorded in addition to the following information: type of eluent used, system number, date of analysis, and retention time.
- 22.3 All calculations and the type of method for determining concentration must be recorded in the analyst's notebook. Any unusual problems or conditions must also be noted.
- 22.4 Record all maintenance performed on the instrument in the maintenance logbook for this particular instrument.
- 22.5 Record all sample injections, including quality control samples, performed by the instrument in the injection logbook for this particular instrument.
- 22.6 It is imperative the project documentation be updated following each sample.

22.7 Analysts will copy raw instrument and QC files to a designated corporate network shared drive at the completion of each analysis sequence or batch. Primary data reviewers will use the data on the shared network drive for their data review process. The completed data packages ready for upload into the ERG LIMS system will be retained on the network drive as the backup for this data.

All processed data are archived in the LIMS on the shared network drive. Data is periodically archived to shared server and compact disc (CD) or digital versatile disc (DVD), verified on the system where the data originated and stored for at least five years in the laboratory. An archive copy of a data package is retained for at least five years in the laboratory data storage.

23.0 REFERENCES

DX-600 Series Chromatography System, and DX-600 Chromatography System Operator's Manual, Dionex Corporation, 117171.
Advanced Gradient Pump Operators Manual, Dionex Corporation, Document No. 034463, 117171.

CARB 039, Extraction and Analysis of Hexavalent Chromium by Ion Chromatography, 1993. A summary is found at <http://www.arb.ca.gov/aaqm/sop/summary/summary.htm>.

ASTM Standard Test Method D7614 for the Determination of Total Suspended Particulate (TSP) Hexavalent Chromium in Ambient Air Analyzed by Ion Chromatography and Spectrophotometric Measurements

24.0 TABLES, DIAGRAMS, FLOWCHARTS, VALIDATION DATA



Table 24-1. Summary of Quality Control Procedures for Hexavalent Chromium Analysis

Parameter	Frequency	Acceptance Criteria	Corrective Action
Sample preparation, standard preparation, instrument conditions	Every Data Package	In Data Packet and/or notebook. Meets SOP ERG-MOR-063 criteria.	Complete documentation in the appropriate data package or notebook
All sample injections, including quality control samples	Every Data Package or injection sequence	In Data Packet and/or injection log. Meets SOP ERG-MOR-063 criteria.	Complete documentation in the appropriate data package or injection log.
Type of eluent used, system number, date of analysis, and retention time.	Every Data Package	In Data Packet and/or notebook. Meets SOP ERG-MOR-063 criteria.	Complete documentation in the appropriate data package or notebook
Calculations and method for determining standards concentration	Every Data Package or Sequence	In Data Packet and/or notebook. Meets SOP ERG-MOR-063 criteria.	Complete documentation in the appropriate data package or notebook
COCs	In Data Packet	In Data Packet	Complete documentation in the appropriate data
Initial 5-point calibration	Before every sequence	Correlation coefficient ≥ 0.995 ; RE < 20%	1) Repeat analysis of calibration standards 2) Reprepare calibration standards and reanalyze
Initial Calibration Verification (ICV)	Before every sequence, following the initial calibration	Recovery 85-115%	1) Repeat analysis of initial calibration verification standard 2) Repeat analysis of calibration standards 3) Reprepare calibration standards and reanalyze



**Table 24-1. Summary of Quality Control Procedures for Hexavalent Chromium Analysis
 (Continued)**

Parameter	Frequency	Acceptance Criteria	Corrective Action
Initial Calibration Blank (ICB)	One per Batch, following the ICV	Analyte must be \leq MDL	1) Reanalyze 2) Reprepare blank and reanalyze 3) Correct contamination and reanalyze blank 4) Flag data of all samples in the batch
Continuing Calibration Verification (CCV)	Every 10 injections and at the end of the sequence	Recovery 85-115%	1) Repeat analysis of CCV 2) Reprepare CCV 3) Flag data bracketed by unacceptable CCV
Laboratory Control Sample (LCS)	Two per sample batch, up to 20 samples.	Recovery 80-120%	1) Reanalyze 2) Reprepare standard and reanalyze 3) Flag data of all samples since the last acceptable LCS
Method Blank (MB)	One per batch	Analyte must be \leq MDL	1) Reanalyze 2) Flag data for all samples in the batch
Replicate Analysis	Duplicate/Collocate and/or replicate samples only	RPD \leq 20% for concentrations greater than 5 x the MDL.	1) Check integration 2) Check instrument function 3) Flag samples
Continuing Calibration Blank (CCB)	After every CCV and at the end of the sequence	Analyte must be \leq MDL	1) Reanalyze 2) Reprepare blank and reanalyze. 3) Correct contamination and reanalyze blank 4) Flag data of all samples in the batch

Figure 24-1. Flowchart for Hexavalent Chromium Samples

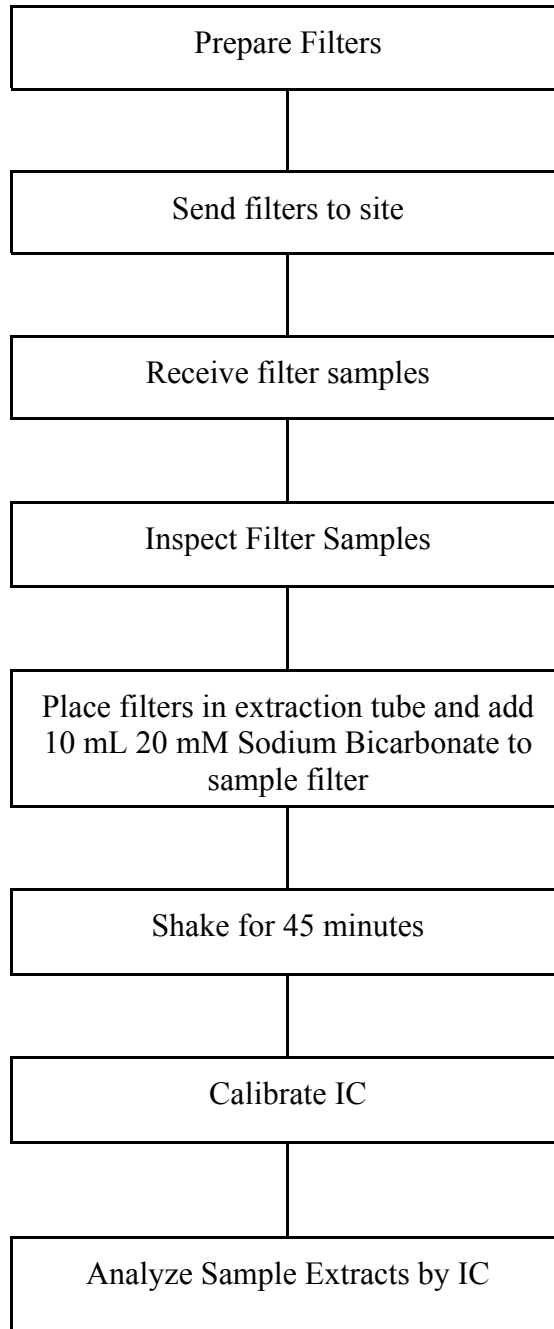



Table 24-2. Hexavalent Chromium Quality Control Review Checklist

Sequence ID: _____ Instrument: _____ Batch: _____
 Cal Curve (Method): _____ Analyst: _____ Date: _____
 10% Review Sample IDs: _____ Reviewer: _____ Date: _____
 Optional 1% Review Sample IDs: _____ Reviewer: _____ Date: _____

Parameter	Acceptance Criteria	Analyst Check (Initials and Date)	Task Lead/Data (Initials and Date)	10 % QA Review (Initials and Date)	1% Optional QA Review (Initials and Date)	Comments
All sample injections, including quality control samples	In Data Packet and/or injection log meets SOP ERG-MOR-063 criteria					
COCs included and sample volume correct	Lab receipt acknowledged. LIMS number added to COC. Sample volume correct.					
Initial 5-point calibration	Correlation coefficient ≥ 0.995 and RE <20%					
Initial Calibration Verification (ICV) following int. calibration	Recovery 85-115%					
Blanks (ICB/CCB) following ICV/CCV	Analyte must be \leq MDL					
Continuing Calibration Verification (CCV) every 10 injections and at the end of the sequence	Recovery 85-115%					



Parameter	Acceptance Criteria	Analyst Check (Initials and Date)	Task Lead/Data (Initials and Date)	10 % QA Review (Initials and Date)	1% Optional QA Review (Initials and Date)	Comments
Laboratory Control Sample one per 10 samples	Recovery 80-120%					
Method Blank one per batch	Analyte must be \leq MDL					
Replicate Analysis	RPD \leq 20% for concentrations $>$ 5 x the MDL.					
Manual Integration	Per SOP ERG-MOR-097					
Manual Check of Calculations	Manual check must agree with computer generated result					
Check Qualifiers	Check to make sure LIMS data flags are correct					

Review checklist from SOP or equivalent must be completed by primary data reviewer/TL/QA.